

Ingersoll-Rand®

Industrial Bolting Solutions



Contents



3/8"-3/4" Class Impacttools™

- Introduction/Product Overview 2
- 3/8" Class Impacttools 4
- 1/2" Class Impacttools 6
- 5/8" and 3/4" Class Impacttools 9-10



1"-3 1/2" Class Impacttools

- Introduction/Product Overview 11
- 1" Class Impacttools 12-13
- 1 1/2" Class Impacttools 14
- 2 1/2" and 3 1/2" Class Impacttools 15
- Impactool Selection Guide 16-17

The new **IR Ingersoll Rand** corporate and brand identity, introduced in 2000, is now being incorporated into product identification and packaging, as well as all communications. While most product photography in this catalog still reflects the previous symbol and logotype signature, you will soon see our new look on everything IR.



Torque Control Impacttools

Introduction/Product Overview	18
Torque Control Impacttools	19-20



Electric Impacttools

Introduction/Product Overview	21
Electric Impacttools	22
Quick Reference/Index to Impacttool Models	23
Pressure Feed Lubrication and Power Regulator Systems	23



Impactool Sockets and Accessories

Introduction	24
Sockets and Accessories	25-30
Balancers	31-34
Comfort Grips	35
Blow Guns	35
Lubricants	36-37
Tune-up Kits	37
Hose Couplings	38-39

Impacttools Index	40
-----------------------------	----

Introduction



Impactools

They're the hardest-working tools of all. Nothing cuts as much time, or packs more labor-saving power than the Impactool.

Imagine the manual process of a hammer striking against a hand wrench to tighten or loosen nuts and bolts. Then consider the sheer size and scope of those bolts — up to 4 inches in diameter — joining parts and components literally weighing tons, and exerting even greater forces. No small task, but one mastered by tools that create incredible energy out of compressed air or electricity, converting motor torque into a series of powerful rotary blows.

For almost seventy years, Ingersoll-Rand has pioneered the development and advancement of Impactools, and today leads the industry with the most complete product selection available. Throughout this catalog, you will find two different types of IR Impactools in three different performance rankings, designed to match the full spectrum of applications.

Two Different Types

Conventional Impactools, in most cases, provide a torque output setting, but rely largely on operator judgment to determine when a fastener is sufficiently tightened. These are the most popular Impactools, and include air as well as electric models.

Torque Control Impactools (air only) provide automatic shutoff upon reaching a preset torque level. They are designed for applications requiring accurate fastener tightening, and incorporate built-in or detachable torsion bars. Based on their diameter and degree of adjustment, the torsion bar senses a predetermined torque level, and mechanically signals an internal shut-off device to prevent over-torquing.

Three Different Rankings

Three different rankings help to define the IR line of Impactools:

- **Super Duty Tools** are intended for high volume production or heavy maintenance and construction, where ultimate performance and durability are required. These tools incorporate a number of unique added features, as well as the finest materials and bearings, tightest tolerances, and most powerful impact mechanisms.
- **Heavy Duty Tools** are well-suited to medium volume production or general maintenance and construction tasks, and offer a good balance between performance and economy.
- **Standard Duty Tools** are intended for less frequent use, involving lighter materials.

Choices for Every Application

Still more choices exist, with a variety of Impactool configurations designed to suit the particular job at hand — for example ...small and medium-sized tools with straight or pistol-grip handles...and larger models with inside trigger, outside trigger, or lever throttle handles. Drive sizes range from 3/8-inch to 3 1/2-inch square drive, and also include spline drives for maximum power transmission in demanding applications. In addition, you can specify certain tools with quick-change anvils for use with extended socket devices, special screwdriver bits, wood augers, and more.

Seventy Years of Leadership

Throughout its history, Ingersoll-Rand has earned a global reputation for creating tools that solve problems, build productivity, and put more power in the hands of the worker. The development of IR Impactools is a particularly strong case in point.

Air Power

Invented by Robert Pott in the early 1930s, the first Impactool was electrically powered, and replaced a manual, labor-intensive process for applications in the agricultural industry. The tools quickly became popular in heavy industrial applications, proving their value in railroad maintenance, bridge construction, refineries, and many other roles. Ingersoll-Rand consulted with Pott and suggested the use of compressed air as a power source, with a new air motor package that the company had designed. Ingersoll-Rand later acquired the original Impactool patent

rights from Pott, and began testing its own designs. In 1934, IR introduced its first air Impactool models, in 3/4-inch drive sizes.

Impactool Evolution

Several years later, IR replaced the original impact mechanism with its own ball and cam design, utilizing two steel balls trapped in opposing helical ball races on the hammer and cam. Shortly thereafter, IR replaced the gear-driven forward/reverse mechanism by simply changing the flow of air to the motor. This power package forms the basis for many of today's Impactools.

Throughout the 1950s and '60s, IR continued to expand its Impactool offerings as new and different applications arose. New advancements included the first torque control tools, designed to stop at predetermined settings, as well as numerous refinements to impact power mechanisms.

Ingersoll-Rand revolutionized Impactool design in the 1970s with the development of the twin-hammer mechanism, extracting more power with fewer moving parts than ever before. Two hammers strike instantaneous, balanced blows to the anvil lobes, generating increased torque with minimal vibration. And today, the advancements continue. The IR2904, 2131, and 2925 Series Models all deliver more power, comfort, and control than anything else in their respective classes. All reflect the IR philosophy of **High Performance Ergonomics** — user oriented design that provides real-world productivity benefits... based on a systematic, objective measure of ergonomic factors for validation and value.

In general, Ingersoll-Rand Impactool mechanisms can be identified by the first one or two digits of the model number:



- Twin-hammer: "2" (except 2902, 2903)
- Jumbo hammer: "17" (plus 2902, 2903)
- Ball and cam: "5" (plus electric Impacttools)

Make the Right Choice

On the following pages, you will find a detailed review of the complete Ingersoll-Rand Impactool line, including performance specifications, special features, standard equipment, and relevant accessories. We have also provided an Impactool Selection Guide on pages 16-17. This will assist in the selection process by defining the following considerations:

- Diameter of fastener being used
- Grade of fastener being used
- Torque control vs. conventional
- Required torque (if applicable)



The selection guide will indicate recommendations based on types of fasteners and tools, using examples from the IR product line carrying the Super Duty rating. However, please refer to the tool specification pages for information on full line availability. In addition, check the Quick Reference on page 23.

IR Impactools. The hardest-working tools of all, backed by the best support in the industry.



High Performance Ergonomics

Three Types of Impactool Mechanisms



Twin-Hammer

A simplified, yet highly effective design that holds each of the reversible hammers

in full engagement or disengagement with centrifugal force. The twin-hammer mechanism delivers more power per pound, and is less sensitive to air pressure fluctuations than any other design.

- Smooth, balanced blow
- High power-to-weight ratio
- Suitable for hard or soft-draw applications



Jumbo Hammer

Similar in concept to the twin-hammer mechanism, but employing a single hammer.

- Simplified design
- Reversible hammers
- Direct drive

Ball and Cam

Precision mechanism converts motor torque into powerful rotary impacts. A planetary gear drive delivers smooth, constant speed from the motor. The ball and cam mechanism is ideal for soft draw applications, and is utilized in larger Impacttools, as well as in all torque control and electric Impacttools.

- Air or electric
- Does not stall
- A time-tested design



Configurations

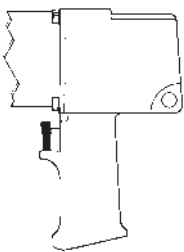

Pistol

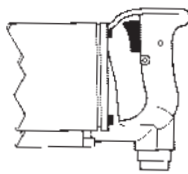

Inside Grip

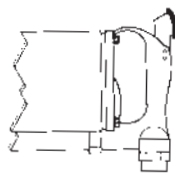

Outside Grip

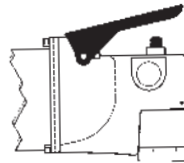

Straight

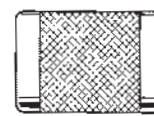

Quick Change



Square Drive



Spline Drive

3/8"-3/4" Class Impacttools

Ingersoll-Rand's wide range of Impacttools offers you the flexibility you need to fit even your most unique applications properly. From applications involving lighter materials and less frequent use to assembly or even maintenance, repair, and operation (MRO) applications, we've got the right tool for the job. Our product selection covers the full range of drive sizes and configurations. In this section, choose from 3/8-inch drive models such as the compact 2904 to IR's 3/4-inch class Series 2925.



3/8" Class Impacttools



● 2902P1



■ 1702P4



▲ 2904P1



★ 1702SB1

Hanger not included

Features

- Twin-hammer impact mechanism on Series 2904
- Jumbo Hammer impact mechanism on Series 2902 and 1702
- Durable epoxy-coated motor housing and handle
- Plated steel hammer case
- Pressure-feed impact mechanism lubrication

Standard Equipment

Series 2902 and 2903

- 1/4" NPT inlet
- Steel hammer case
- Integral muffler
- Built-in power regulator
- Pin-type socket retainer

Series 2904

- 1/4" NPT inlet
- Steel hammer case
- Composite housing
- Power management system

Series 1702

- 1/4" NPT inlet
- Steel hammer case
- B1 and B3 model: Inside throttle and dead handle
- Pin-type socket retainer
- Built-in power regulator (P)

Equipment at Extra Price

- Vertical hanger No. 1901-365 (B)
- Exhaust muffler kit No. 212-K23 (P)
- Horizontal hanger No. 1901-366

Series 2902

- Vertical hanger No. 1901-365 (B)
- Horizontal hanger No. 1901-366 (P&B)

Series 2903

- Vertical hanger No. 2908-365
- Horizontal hanger No. 1901-366

Model	Drive Description	Handle	Free Speed rpm	Impacts per minute	Maximum Torque		Recomm. Torque Range		Weight, less socket		Length, less socket		Side to Center Distance		Size	Hose	Recomm. CFM	
					ft.-lb.	Nm	ft.-lb.	Nm	lb.	kg	in.	mm	in.	mm	in.	mm		
Super Duty Impacttools																		
● 2902P1	3/8" square	Pistol	10,000	1500	140	190	20-120	27-163	2 1/2	1.25	5 1/2	140	1 3/8	35	5/16	8	15	
2903P2	3/8" square	Pistol	6000	1200	205	278	30-170	41-230	4 13/16	2.18	5 5/8	143	1 3/8	35	3/8	10	21	
▲ 2904P1	3/8" square	Pistol	14,500	1500	230	313	25-200	34-270	2.65	1.20	5 3/4	146	1 1/8	29	3/8	10	18	
	Reverse Bias				260	354												
2904P4	1/4" hex QC	Pistol	14,500	1500	260	354	25-200	34-270	2.65	1.20	5 3/4	146	1 1/8	29	3/8	10	18	
	Reverse Bias																	
Heavy Duty Impacttools																		
★1702SB1	3/8" square	Straight	10,000	1500	105	142	13-85	18-115	2 1/2	1.12	5 7/8	149	1	25	5/16	8	13	
1702P1	3/8" square	Pistol	10,000	1500	125	170	20-100	27-136	2 3/4	1.25	5 1/2	140	1 3/8	35	5/16	8	15	
■ 1702P4	1/4" hex QC	Pistol	10,000	1500	125	170	20-100	27-136	2 3/4	1.25	5 1/2	140	1 3/8	35	5/16	8	15	

"QC" designates a Quick Change chuck.

Note: All of the above square drive Impacttools furnished with pin-type retainer. Performance figures are at 90 psi (620kPa) air pressure.

1/2" Class Impacttools

Features

- Jumbo hammer impact mechanism on Series 2903
- Rugged twin-hammer impact mechanism on 2906
- Durable epoxy-coated motor housing and handle
- Plated steel hammer case
- Pressure-feed impact mechanism lubrication

Standard Equipment

Series 2903

- 1/4" NPT inlet
- Steel hammer case
- Built-in lubricator
- Integral muffler
- Built-in power regulator

Series 2131

- 1/4" NPT inlet
- Steel hammer case
- Composite housing
- Built-in power regulator

Series 2906

- 1/4" NPT inlet
- Steel hammer case
- Built-in lubricator
- Integral muffler
- Two-piece motor housing
- Built-in power regulator



▲ 2903P1



★ 2906P1

Series 2707

- 1/4" NPT inlet
- Steel hammer case
- Built-in power regulator

Models 2705A1

- 1/4" NPT inlet
- Steel hammer case
- Built-in power regulator



● 2131P

Equipment at Extra Price

Series 2903, 2908

- Vertical hanger No. 2908-365

Series 2705

- Vertical hanger No. 904-366

Series 2131

- Vertical hanger No. 2131-366

Model	Drive Description	Handle	Free Speed rpm	Impacts per minute	Maximum Torque		Recomm. Torque Range		Weight, less socket		Length, less socket		Side to Center Distance		Size Hose Recomm. CFM		
					ft.-lb.	Nm	ft.-lb.	Nm	lb.	kg	in.	mm	in.	mm	in.	mm	
Super Duty Impacttools																	
★ 2906P1	1/2" square	Pistol	5000	1200	500	678	40-350	54.2-475	6	2.72	67/8	175	11 ¹¹ / ₃₂	34	3/8	10	23
▲ 2903P1	1/2" square	Pistol	6000	1200	220	298	30-185	41-250	4 ³ / ₁₆	2.18	5 ⁵ / ₈	143	1 ³ / ₈	35	3/8	10	21
Heavy Duty Impacttools																	
2707A1	1/2" square	Pistol	7750	1300	450	610	40-275	54-373	6	2.72	6 ¹ / ₂	165	1 ³ / ₈	35	5/16	8	26
Standard Duty Impacttools																	
● 2131P	1/2" square Reverse Bias	Pistol	9500	1200	450	610	50-400	68-542	4 ¹ / ₂	2.04	6 ⁷ / ₈	174	1 ³ / ₈	35	3/8	10	27
2131P7	7/16" hex QC Reverse Bias	Pistol	9500	1200	450	610	50-400	68-542	4 ¹ / ₂	2.04	6 ⁷ / ₈	174	1 ³ / ₈	35	3/8	10	27
2705A1	1/2" square	Pistol	8500	1200	400	542	40-200	54-271	5 ⁵ / ₈	2.55	6 ³ / ₄	171	11 ¹¹ / ₃₂	34	3/8	10	23
2904P2	1/2" square Reverse Bias	Pistol	14,500	1500	230	313	25-200	34-270	2.65	1.20	5 ³ / ₄	146	1 ¹ / ₈	29	3/8	10	18

All of the above square drive Impacttools furnished with pin-type retainer. Performance figures are at 90 psi (620 kPa) air pressure.

5/8" and 3/4" Class Impacttools

Introducing the IR2925B.

1700 ft.- lbs. of max torque ÷ 14 lbs. of tool

With an ergonomically designed handle and grip, and a trim, 14-lb. weight, the IR2925B 1" Impacttool will ease the burden of exhausting steel erection, bridge maintenance, power generation and petrochemical applications.



Standard dead handle allows a comfortable and balanced grip, with even weight distribution. Adjustable 360° positioning.

Although it weighs approximately 30% less than the lightest competitor, the IR2925B generates an incredible 1700 ft.-lbs. of torque in reverse, thanks to a compact, efficient air motor that achieves peak torque output quicker than other tools.

Other features include the Corrode-X corrosion resistant motor, valving and airflow components, Ingersoll-Rand's enhanced geometry twin-hammer mechanism, an easy-access power management system, and a rear air inlet that keeps the hose in line and out of the way.

The IR2925B – More power – More speed – More comfort – Less weight. Forward bias and outside trigger models are also available. And, the IR2925P Series offers similar advantages in a pistol-grip configuration.



The three-position power management system is conveniently located inside the handle for one-handed access to three levels of power in forward, and one in reverse.

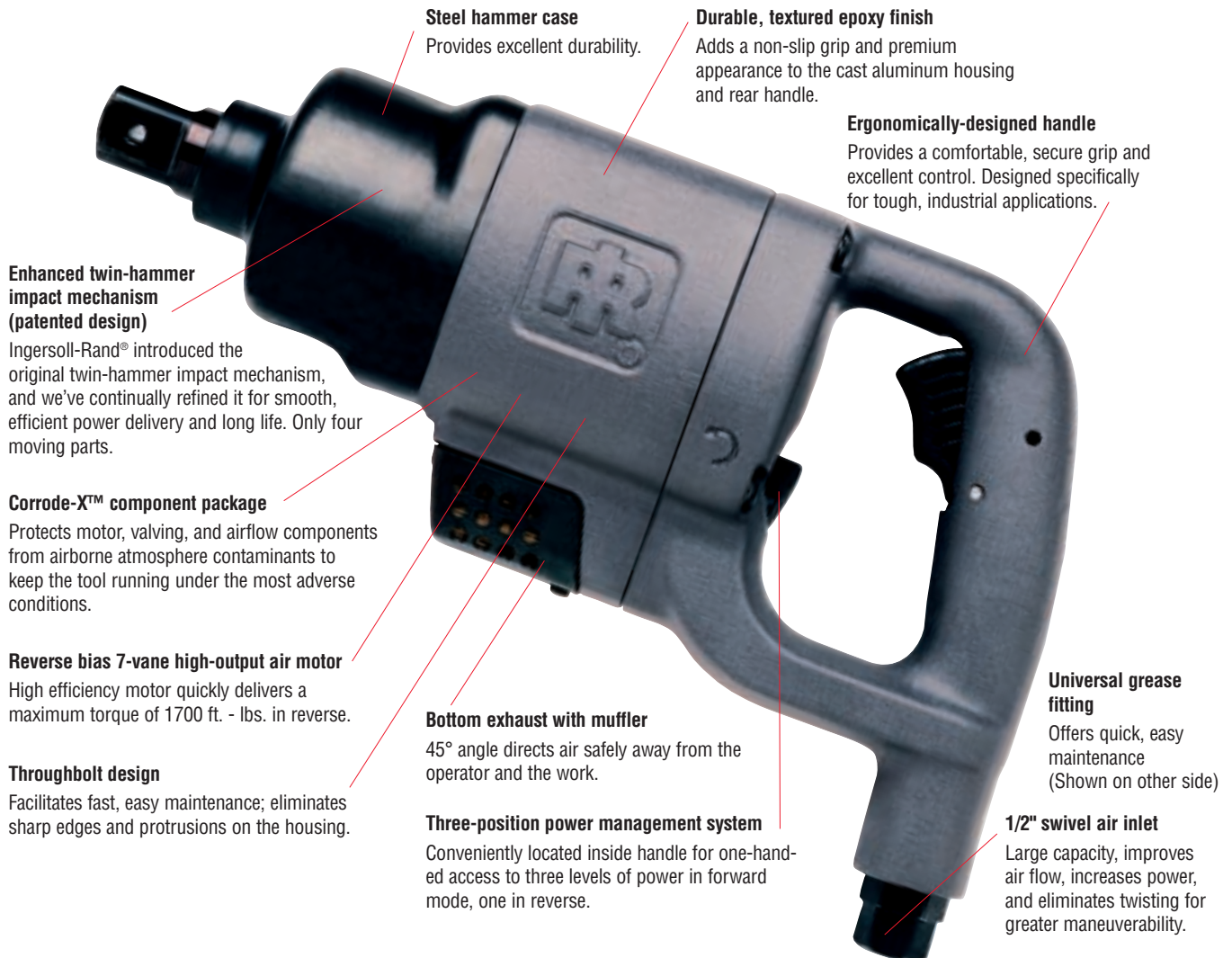

IR2925P

A new generation of Impacttools

The unique features of the 2925 Series extend to pistol grip configurations in the 2925P Models. They offer an unmatched combination of performance and control, with the durability to withstand the toughest operating conditions.

External features include:

- Ergonomic handle design
 - Smooth contoured profile with integral grip ledge
 - Three-piece housing
 - Handle exhaust
 - 360° swivel air inlet
 - Contoured trigger
 - Minimum side-to-center distance
 - Enhanced pressure-feed lubrication system
 - Low profile reverse lever
 - Three-position power regulation and forward/reverse control
- Position #1 = Full
 #2 = Approx. 88%
 #3 = Approx. 77%

Internal features include:

- 1 Enhanced twin-hammer impact mechanism
- 2 Supermotor™
- 3 Through-bolt construction
- 4 Corrode-X™ (Components completely impervious to corrosive contaminants)
- 5 Tilt throttle
- 6 Reverse or forward bias
- 7 Concentric cylinder design
- 8 Composite vanes
- 9 Balanced horizontal suspension bail (opt.)
- 10 Piped-away exhaust (opt.)

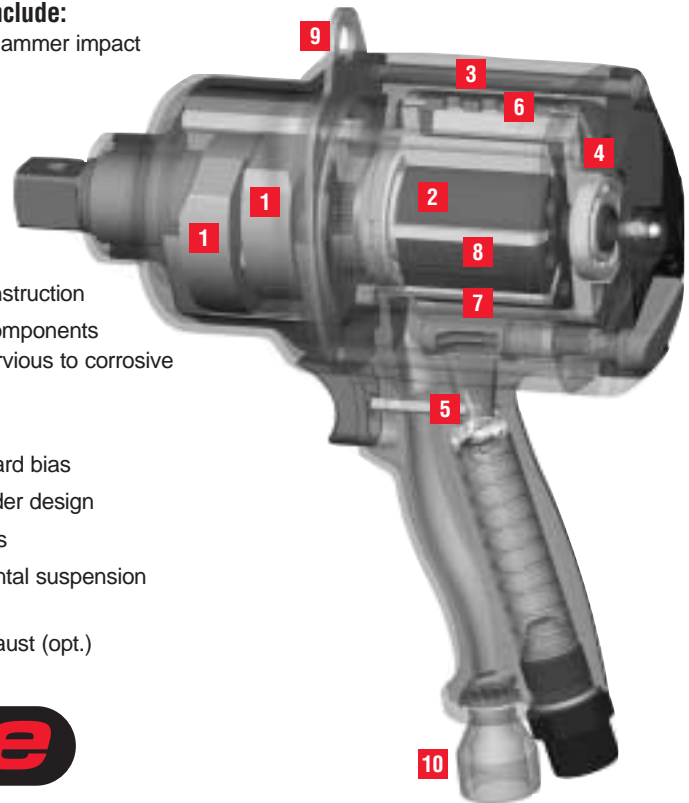

High Performance Ergonomics

IR2161

The IR2161 models

The IR2161 heavy duty models are ideal for applications a little less demanding than those for the IR2925.

Features that distinguish the IR2161 from the IR2925 models include:

- Enhanced single-hammer mechanism
 - Contoured trigger
 - Minimum side-to-center distance
 - Enhanced pressure-feed lubrication system
 - Three-position power regulation and forward/reverse control
 - Ribbed lever surface
- Position #1 = Full
 #2 = Approx. 88%
 #3 = Approx. 77%



- Maximum torque of 1250 ft.-lbs.
- Smooth, high-gloss cast aluminum finish
- 6-Vane high-output air motor
- Smooth, contoured exterior profile

External features include:

- Ergonomic handle design
- Smooth contoured profile
- Three-piece housing
- Handle exhaust
- 360° swivel air inlet

Internal features include:

- An enhancement to the original single-hammer mechanism provides increased durability and performance (patent applied for)
- 6-Vane high-output air motor
- Through-bolt construction
- 360° swivel air inlet
- Tilt throttle
- Concentric cylinder design
- Balanced horizontal suspension bail (opt.)
- Piped-away exhaust (opt.)



5/8" and 3/4" Class Impacttools



◆ 2925B2

Features

Models 2161P, 2171P

- Conventional cast aluminum finish
- Full contoured housing shape
- Ergonomically-designed handle
- 360° swivel inlet
- Handle exhaust
- Enhanced single-hammer impact mechanism
- 6-Vane high-output air motor

Series 2908

- Durable epoxy-coated motor housing and handle
- Plated steel hammer case
- Twin-hammer impact mechanism
- Pressure-feed impact mechanism lubrication

Series 2920B

- Muffled exhaust reduces operator fatigue
- Slip fit motor for easy maintenance
- Tilt throttle on pistol models for maximum control
- Two-piece motor housing on pistol models
- Durable epoxy-coated motor housing and handle
- Plated steel hammer case
- Twin-hammer impact mechanism
- Pressure-feed impact mechanism lubrication

Series 2925

- Integral grip ledge
- Three-piece housing
- Handle exhaust
- Minimum side to center distance
- Three position power regulation
- Forward/reverse control
- Enhanced twin-hammer impact mechanism
- 7-Vane high-output air motor
- Corrode-X™

Series 2925B

- 1/2" swivel air inlet
- Enhanced twin-hammer impact mechanism

- Corrode-X™ component package
- Reverse bias 7-vane high-output air motor
- Throughbolt design
- 45° bottom exhaust with muffler
- Three-position power management system
- Universal grease fitting
- Steel hammer case
- Durable, textured epoxy finish
- Ergonomically-designed handle

Standard Equipment

Models 2161P, 2171P

- 3/8" NPT inlet
- Steel hammer case
- Integral muffler
- Built-in power regulator
- Through-hole socket retainer

Series 2908

- 3/8" NPT Inlet
- Pin-type socket retainer
- Steel hammer case
- Integral muffler
- Built-in lubricator
- Built-in power regulator

Series 2925

- 3/8" NPT Inlet
- Steel hammer case
- Integral muffler
- Built-in power regulator
- Through-hole socket retainer

Series 2920B

- 3/8" NPT inlet
- Steel hammer case
- Integral muffler
- Built-in lubricator
- 90° Angle drive (Model 2920B9 only)
- 2920B3 includes 834-48 straight handle
- 2920B9 includes spade handle T15-41

Series 1720

- 3/8" NPT inlet
- Steel hammer case



■ 2925P1

- B3 model: Inside throttle and dead handle

Equipment at Extra Price

Models 2161P, 2171P

- Piped-away exhaust kit No. 2161-123
- Horizontal suspension bail No. 2161-366
- Boot 2161-P32

Series 2908

- Vertical hanger No. 2908-365

Series 2925

- Piped-away exhaust kit No. 2161-123
- Horizontal suspension bail No. 2161-366
- Number 4 spline anvil No. 2910-A526

Series 2920B

- 2910B-726-6: 6" extended 3/4" anvil
- Horizontal hanger No. 910-366
- 5/8" hex quick change anvil No. 2910B-A926-10

Series 2920B

- Power regulator valve kit No. 2920-K32

Series 1720

- 3/4" drive x 6" (152 mm) hog ring style
- Extended anvil No. 265-A626-6
- Horizontal hanger No. 910-366
- Power regulator Kit No. 2920-K329
- Reverse valve Kit No. 1720-K329
- Dead handle 834-48
- Dead handle bracket 2910B-364

(Please turn page for specifications)

5/8" and 3/4" Class Impacttools

Model	Drive Description	Handle	Free Speed rpm	Impacts per minute	Maximum Torque		Recomm. Torque Range		Weight, less socket		Length, less socket		Side to Center Distance		Size Hose Recomm. CFM		
					ft.-lb.	Nm	ft.-lb.	Nm	lb.	kg	in.	mm	in.	mm	in.	mm	
Super Duty Impacttools																	
2925P1	3/4" square	Pistol	5200	1050	1450	1972	350-1100	476-1496	11 ⁷ / ₈	5.39	8 ⁷ / ₈	225	1 ³ / ₄	44	1/2	13	60
2925P3	1" square	Pistol	5200	1050	1450	1972	350-1100	476-1496	11 ⁷ / ₈	5.39	8 ⁷ / ₈	225	1 ³ / ₄	44	1/2	13	60
2925RBP1	3/4" square Reverse Bias	Pistol	5200	1050	1600 R 1300 F	2176 1768	400-1400 300-950	544-1904 408-1292	11 ⁷ / ₈	5.39	8 ⁷ / ₈	225	1 ³ / ₄	44	1/2	13	60
2925B2	1" square	Grip I.T.	6500	900	1600	2170	350-1400	475-1904	14	6.35	12 ³ / ₈	314	1 ⁵ / ₈	41	1 ¹ / ₂	13	60
2925RB2	1" square Reverse Bias	Grip I.T.	6500	900	1700 1500	2305 2034	F300-1300 R400-1500	407-1763 544-2034	14	6.35	12 ³ / ₈	314	1 ⁵ / ₈	41	1 ¹ / ₂	13	60
2925A2	1" square	Grip O.T.	6500	900	1600	2170	350-1400	475-1904	14	6.35	12 ³ / ₈	314	1 ⁵ / ₈	41	1 ¹ / ₂	13	60
2925RA2	1" square Reverse Bias	Grip O.T.	6500	900	1700 1500	2305 2034	F300-1300 R400-1500	407-1763 544-1904	14	6.35	12 ³ / ₈	314	1 ⁵ / ₈	41	1 ¹ / ₂	13	60
2925RBP3	1" square Reverse Bias	Pistol	5200	1050	1600 R 1300 F	2176 1768	400-1400 300-950	544-1904 408-1292	11 ⁷ / ₈	5.39	8 ⁷ / ₈	225	1 ³ / ₄	44	1/2	13	60
2920B1	3/4" square	Grip	5000	950	1100	1495	250-800	339-1085	13 ³ / ₁₆	5.98	12 ¹ / ₂	318	1 ²⁹ / ₃₂	49	1/2	13	36
2920B3	1" square	Grip	5000	950	1100	1495	250-800	339-1085	13 ³ / ₁₆	5.98	12 ¹ / ₂	318	1 ²⁹ / ₃₂	49	1/2	13	36
◆2920B9	3/4" sq. at 90°	Grip	5000	950	550	949	125-400	203-678	23 ¹¹ / ₁₆	10.75	17 ¹ / ₂	445	1 ¹⁵ / ₁₆	†33	1/2	13	36
2908P2	3/4" square	Pistol	6000	1050	750	1017	100-450	136-610	8 ¹¹ / ₁₆	3.94	7 ¹¹ / ₁₆	195	1 ⁵ / ₈	41	1/2	13	31
2908P1	5/8" square	Pistol	6000	1050	750	1017	100-450	136-610	8 ¹ / ₂	3.86	7 ¹¹ / ₁₆	195	1 ⁵ / ₈	41	1/2	13	31
Heavy Duty Impacttools																	
2161P	3/4" square	Pistol	5750	1025	1250	1700	250-900	340-1224	11 ¹ / ₄	5.10	8 ¹ / ₂	216	1 ³ / ₄	44	1/2	13	55
2171P	1" square	Pistol	5750	1025	1250	1700	250-900	340-1224	11 ¹ / ₄	5.10	8 ¹ / ₂	216	1 ³ / ₄	44	1/2	13	55
1720P1	3/4" square	Pistol	5500	1000	1000	1360	200-600	271-813	11 ⁷ / ₈	5.39	7 ⁵ / ₈	194	1 ²⁹ / ₃₂	48	1/2	13	40
1720P3	1" square	Pistol	5500	1000	1100	1490	250-750	340-1016	11 ⁷ / ₈	5.39	7 ⁵ / ₈	194	1 ²⁹ / ₃₂	48	1/2	13	40
1720B1	3/4" square	Grip	5500	1000	1000	1360	200-600	271-813	13 ³ / ₁₆	6.27	11 ³ / ₄	299	1 ²⁹ / ₃₂	48	1/2	13	40
1720B3	1" square	Grip	5500	1000	1100	1490	250-750	340-1016	13 ³ / ₁₆	6.27	11 ³ / ₄	299	1 ²⁹ / ₃₂	48	1/2	13	40

Note: IR2925 number 4 spline models are available by converting the standard square drive anvil with number 4 spline anvil part number 2910-A526. The same performance figures apply.

Models 2908P1 and 2908P2 Impacttools furnished with pin-type retainer.

Performance figures are at 90 psi (620 kPa) air pressure.

Angle head gear ratio on model 2920B9 is 2 to 1.

† Side to center distance of angle head. Height of angle head to shoulder of square drive is 3¹/₂" (89 mm).

**2920B9 Hammer Case is plated ductile iron.

◆ Approx. 50% torque reduction.

I.T.: Inside Throttle

O.T.: Outside Throttle

1"-3½" Class Impacttools



You'll master the toughest challenges with IR's 1-inch to 3½-inch Class Impacttools. Designed for high volume production or heavy maintenance and construction applications, these models incorporate the finest materials and most precise tolerances. IR has combined almost seventy years of Impacttool expertise and the finest materials around to produce the best Impacttools the industry has to offer.

1" Class Impacttools



Features

- 1" square drive or No. 5 spline models
- Plated ductile iron hammer case and durable epoxy-coated motor housing and handle
- Twin-hammers mean more power per pound
- Pressure-feed impact mechanism lubrication
- Two-piece motor housing

Standard Equipment

Series 2934

- 1/2" NPT inlet
- Plated cast iron hammer case
- Dead straight handle (A & B models only)
- Spade style dead handle (B9 & P2 models only)
- Integral muffler
- Built-in power regulator (P2 model only)
- 90° Angle drive (Model 2934B9 only)

Standard Equipment

Model 1734A1

- 1/2" NPT inlet
- Plated hammer case

Series 1712

- 1/2" NPT inlet
- Ductile iron hammer case
- B2 model: Inside throttle and spade style dead handle

Equipment at Extra Price

Series 1734

- No. 5 spline 280-A514-6
- *6" square anvil: 280-726-6
- Hanger: 2934-366
- Exhaust deflector kit: 2934-K23
- Piped-away exhaust with muffler: 2940-KM184
- Piped-away exhaust without muffler: 2940-K184

Series 2934

- 90° Angle drive is available for all square drive models.
- Order angle attachment No. 2934A90

and hex nose hammer case No.

2934-A827. This hammer case must be used to replace the standard hammer case. Note that these items are furnished as standard equipment on Model 2934B9

- *1" drive x 6" (152 mm) extended anvil No. 2934-314-6
 - Horizontal hanger consisting of:
 - One horizontal hanger No. 2934-366
 - Two hanger spacers No. 2934-140
 - Piped-away exhaust muffler kit No. 2940-KM184. (A & B models only)
- ### Series 1712
- *1" drive x 6" (152 mm) extended anvil No. 280-726-6
 - 2934-366 horizontal hanger

Model	Drive Description	Handle	Free Speed rpm	Impacts per minute	Maximum Torque		Recomm. Torque Range		Weight, less socket		Length, less socket		Side to Center Distance		Size Hose Recomm. CFM	
					ft.-lb.	Nm	ft.-lb.	Nm	lb.	kg	in.	mm	in.	mm	in.	mm

Super Duty Impacttools

2934A2	1" square	Grip O.T.	6600	750	1500	2030	500-1100	678-1490	18½	8.39	11¼	286	2⅜	56	¾	19	47
2934B1**	No. 5 spline	Grip I.T.	6600	750	1500	2030	500-1100	678-1490	18½	8.39	11¼	286	2⅜	56	¾	19	47
2934B2	1" square	Grip I.T.	6600	750	1500	2030	500-1100	678-1490	18½	8.39	11¼	286	2⅜	56	¾	19	47
● 2934B9	1" sq. at 90°	Grip I.T.	5300	780	750	1624	250-500	678-1355	35¾	16.2	18⅝	473	1⅝	141	¾	19	47
▲ 2934P2	1" square	Pistol	5300	825	1500	2030	500-1100	678-1490	20	9.07	8⅝	219	2⅜	56	¾	19	47

Heavy Duty Impacttools

1734A1**	No. 5 spline	Grip O.T.	6000	800	1400	1904	450-1000	612-1860	18⅜	8.34	11¼	286	2⅜	56	¾	19	47
1712B2	1" square	Grip I.T.	6000	800	1350	1836	450-1000	612-1860	18¼	8.28	11¼	286	2⅜	56	¾	19	47
1712P2	1" square	Pistol	6000	800	1350	1836	450-1000	612-1860	18¼	8.28	11¼	286	2⅜	56	¾	19	56

*Approx. 15% torque reduction.

Performance figures are at 90 psi (620 kPa) air pressure. Angle head gear ratio on model 2934B9 B is 1 to 1.

**No. 5 spline 1⅝" OD 14 teeth.

† Side to center distance of angle head. Height of angle head to shoulder of square drive is 4⅜" (111 mm).

I.T.: Inside Trigger
O.T.: Outside Trigger



● 2940B1



▲ 2940P2

Features

- Choice of 1" square drive or No. 5 spline
- Plated ductile iron hammer case and durable epoxy-coated motor housing and handle
- Twin-hammers mean more power per pound
- Two-piece motor housing

Standard Equipment Series 2940

- 1/2" NPT inlet
- Plated cast iron hammer case
- Integral muffler
- Built-in lubricator
- Straight dead handle (A & B models only)
- Spade style dead handle (P2 Model only)
- Integral power regulator (P2 Model only)

Equipment at Extra Price Series 2940

- Piped-away exhaust muffler kit No. 2940-KM184 (A & B models only)
- Horizontal hanger consisting of
 - One horizontal hanger No. 2934-366
 - Two hanger spacers No. 2934-140
- *1" drive x 6" (152 mm) extended anvil No. 2940-314-6

Model	Drive Description	Handle	Free Speed rpm	Impacts per minute	Maximum Torque		Recomm. Torque Range		Weight, less socket		Length, less socket		Side to Center Distance		Size Hose Recomm. CFM		
					ft.-lb.	Nm	ft.-lb.	Nm	lb.	kg	in.	mm	in.	mm	in.	mm	
2940A1**	No. 5 spline	Grip O.T.	5000	850	2000	2710	1000-1600	1360-2170	22	9.98	12 ¹ / ₄	311	2 ³ / ₁₆	56	3/4	19	58
2940A2	1" square	Grip O.T.	5000	850	2000	2710	1000-1600	1360-2170	22	9.98	12 ¹ / ₄	311	2 ³ / ₁₆	56	3/4	19	58
● 2940B1**	No. 5 spline	Grip I.T.	5000	850	2000	2710	1000-1600	1360-2170	22	9.98	12 ¹ / ₄	311	2 ³ / ₁₆	56	3/4	19	58
2940B2	1" square	Grip I.T.	5000	850	2000	2710	1000-1600	1360-2170	22	9.98	12 ¹ / ₄	311	2 ³ / ₁₆	56	3/4	19	58
▲ 2940P2	1" square	Pistol	4000	810	2000	2710	1000-1600	1360-2170	22 ⁷ / ₈	10.4	9 ⁷ / ₈	251	2 ³ / ₁₆	56	3/4	19	58

*Approx. 15% torque reduction.

**No. 5 spline 1⁵/₈" OD 14 teeth.

Performance figures are at 90 psi (620 kPa) air pressure.

O.T.: Outside Trigger

I.T.: Inside Trigger

1½" Class Impacttools



● 2950B7



▲ 5980A1

Features

Series 2945 and 2950

- Twin-hammers mean more power per pound
- Direct drive for fast rundown
- Durable epoxy-coated motor housing
- Plated ductile iron hammer case
- Pressure-feed impact mechanism lubrication
- Two-piece motor housing

Model 5980A1

- Precision ball and cam impact mechanism

Standard Equipment

Series 2945

- 1/2" NPT inlet
- Straight dead handle
- Plated hammer case
- Built-in lubricator
- Integral muffler

Series 2950

- 1/2" NPT inlet
- Straight dead handle
- Plated hammer case
- Built-in lubricator
- Integral muffler

Model 5980A1

- ¾" NPT inlet
- Aluminum hammer case
- Built-in lubricator
- Horizontal eyebolt
- Vertical eyebolt

Equipment at Extra Price

Series 2945 and 2950

- Piped-away exhaust muffler kit No. 2940-KM184
- Horizontal hanger kit No. 2950-K366

Series 5980A1 and 5982A1

- Dual grip handle No. 5980-48

Model	Drive Description	Handle	Free Speed rpm	Impacts per minute	Maximum Torque		Recomm. Torque Range		Weight, less socket		Length, less socket		Side to Center Distance		Size Hose Recomm. CFM		
					ft.-lb.	Nm	ft.-lb.	Nm	lb.	kg	in.	mm	in.	mm	in.	mm	
2945A7	1½" square	Grip-O.T.	4000	650	2400	3264	1400-1800	1900-2440	30	13.6	13¾	349	2½	64	¾	19	65
2945B1*	No. 5 spline	Grip-I.T.	4000	650	2400	3264	1400-1800	1900-2440	30	13.6	13¾	349	2½	64	¾	19	65
2945B7	1½" square	Grip-I.T.	4000	650	2400	3264	1400-1800	1900-2440	30	13.6	13¾	349	2½	64	¾	19	65
2950A7	1½" square	Grip-O.T.	3750	650	3000	4080	1600-2500	2170-3390	32⅝	14.8	14½	368	2½	64	¾	19	70
2950B1	No. 5 spline	Grip-I.T.	3750	650	3000	4080	1600-2500	2170-3390	32⅝	14.8	14½	368	2½	64	¾	19	70
● 2950B7	1½" square	Grip-I.T.	3750	650	3000	4080	1600-2500	2170-3390	32⅝	14.8	14½	368	2½	64	¾	19	70
▲ 5980A1	1½" square	Lever	830	1000	10,000	13,560	2300-5500	3119-7460	88	39.9	23	584	3⅛	78	1	25	138

Performance figures are at 90 psi (620 kPa) air pressure.
*No. 5 spline 1½" OD 14 teeth.

O.T.: Outside Trigger
I.T.: Inside Trigger

2½" to 3½" Class Impacttools

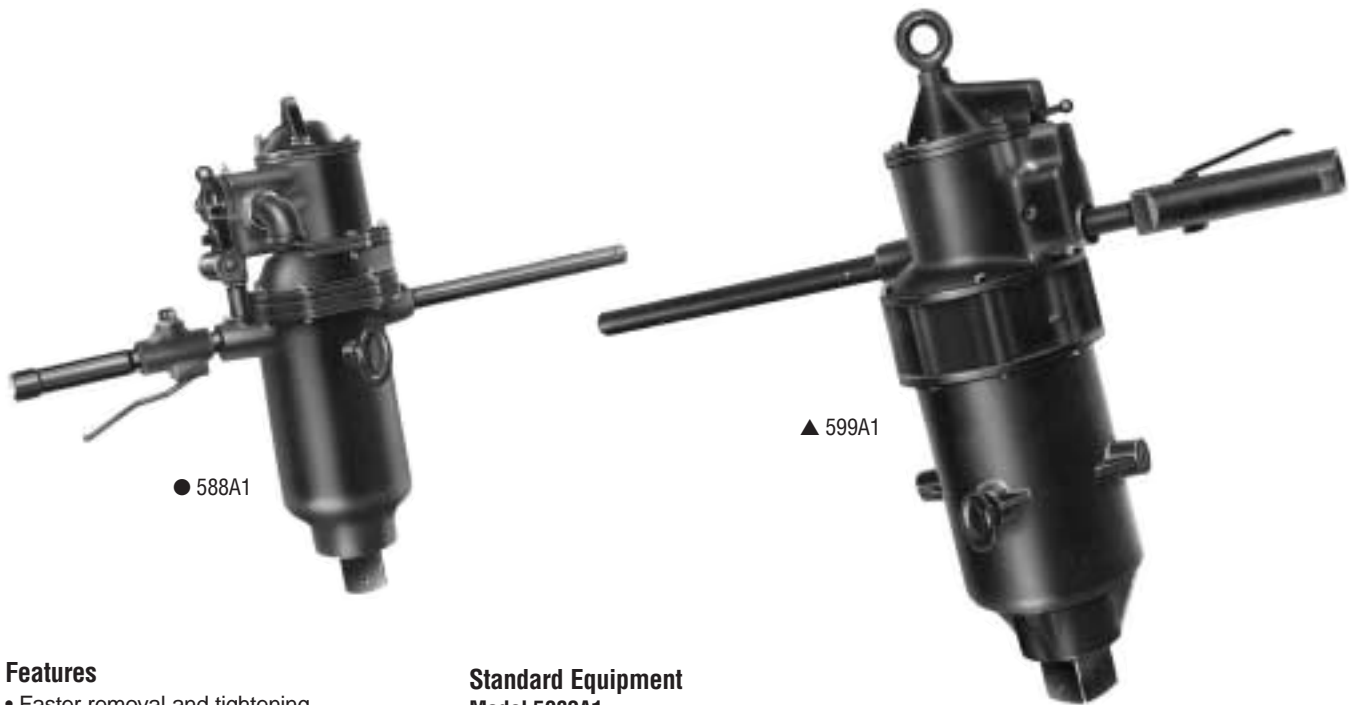

● 588A1

▲ 599A1

Features

- Faster removal and tightening of large (4" [102 mm] and larger) fasteners
- Precision ball and cam impact mechanism
- Portable, easy to handle or suspend
- Model 599A1 is the most powerful Impacttool in the world

Standard Equipment

Model 5982A1

- Lever throttle
- ¾" NPT inlet
- Aluminum hammer case
- Side exhaust
- Dead handle
- Horizontal eyebolt
- Vertical eyebolt

Model 588A1

- Lever throttle
- 1" NPT inlet
- Cast iron hammer case
- Dead handle
- Built-in lubricator
- Horizontal eyebolt
- Vertical hanger

Model 599A1

- Lever throttle
- 1¼" NPT inlet
- Cast iron hammer case
- Dead handle
- Built-in lubricator
- Horizontal eyebolt
- Vertical eyebolt

Equipment at Extra Price

Model 5982A1

- Horizontal hanger
ILA582A1-D366

Model	Drive Description	Handle	Free Speed rpm	Impacts per minute		Maximum Torque		Recomm. Torque Range		Weight, less socket		Length, less socket		Side to Center Distance in. mm	Size Hose Recomm. in. mm	CFM
				ft.-lb.	Nm	ft.-lb.	Nm	lb.	kg	in.	mm					
5982A1	2½" square	Lever	830	850	20,000	27,120	4000-10,000	5424-13,560	120	54.5	25⅜	645	3½	89	1 25	130
● 588A1	2½" square	Lever	355	550	50,000	67,800	12,000-25,000	16,270-33,900	215	97.5	26⅝	676	4	101	1 25	155
▲ 599A1	3½" square	Lever	295	500	80,000	108,500	26,000-42,000	35,250-57,000	599	272	37½	952	6¾	171	1½	38 375

Performance figures are at 90 psi (620 kPa) air pressure.

Impactool Selection Guide

This chart will assist you in recommending a particular Impactool for a specific application. The figures used are based on 70% of the tension proof load of a given size and grade bolt. For example, a Grade 5 bolt has a proof load of 94,200 psi (649,509 kPa). A 1/2"-13 UNC Grade 5 bolt has a tensile stress area — the cross section at the root of the thread — of 0.1282 in.² (82.7 mm²). So therefore it has an actual proof load of 12,076 lbs. (53,715 newtons). 70% of this proof load is 8453 lbs. (14,523 newtons). By looking at the chart, we find that in order to put 8450 lbs. (37,586 newtons) of tension on the 1/2" (13 mm) UNC Grade 5 bolt, we must apply 70 ft.-lbs. (94.9 Nm) torque. To do this, we recommend the Series 2906 Impactool.

It should be remembered that 70% of the proof load is normally the amount of tension needed to assure a properly tightened joint.

Bolt Grade	Bolt Diameter, in.		1/4	5/16	3/8	7/16	1/2	9/16	5/8	3/4	7/8	1	1 1/8	1 1/4
	Bolt Diameter, mm		6	8	10	11	13	14	16	19	22	25	29	32
	Hex Size, Inches	Max.	1/2	19/32	11/16	25/32	7/8	31/32	11/16	11/4	17/16	15/8	113/16	2
		Min.	3/8	15/32	9/16	21/32	3/4	27/32	15/16	11/8	15/16	11/2	111/16	17/8
Grade 1	Torque	ft.-lbs.	3	6	11	18	28	43	55	97	155	230	340	480
		Nm	4.07	8.14	14.9	24.4	38	58.3	74.6	132	210	312	461	651
	Impactool Recommended		2902	2902	2902	2903	2903	2903	2906	2908	2908	2925	2925	2934
	Tension	lbs.	730	1,210	1,800	2,460	3,280	4,200	5,200	7,000	10,600	14,000	18,200	23,000
		kN	3.24	5.38	8.01	10.9	14.6	18.7	23.1	31.1	47.1	62.3	80.9	102
Grade 5	Torque	ft.-lbs.	8	16	28	46	70	110	140	250	405	600	770	1,080
		Nm	10.8	21.7	38	62.4	95	149	190	339	549	814	1,044	1,464
	Impactool Recommended		2902	2902	2902	2903	2906	2906	2908	2925	2925	2934	2934	2940
			2904	2904	2904	2904	2904	2903	2906	2908	2906	2908	1734	1734
	Tension	lbs.	1,900	3,100	4,600	6,350	8,450	10,900	13,500	20,000	27,400	36,000	41,000	52,000
		kN	8.4	13.8	20.4	28.2	37.6	48.5	60	89	122	160	182	231
ASTM-A325	Torque	ft.-lbs.							200	355	570	850	1,060	1,495
		Nm							271	481	773	1,153	1,437	2,027
	Impactool Recommended								2925	2934	2934	2934	2940	2945
									2908	2925	1734	1734		
	Tension	lbs.							19,000	28,000	39,000	51,000	56,000	71,000
		kN							44.5	124	173	227	249	316
Grade BB ASTM-A354	Torque	ft.-lbs.	8	15	27	43	66	106	131	234	376	565	830	1,170
		Nm	10.8	20.3	36.6	58.3	89.5	144	178	317	510	766	1,125	1,586
	Impactool Recommended		2902	2902	2902	2903	2903	2906	2908	2925	2925	2934	2934	2940
			2904	2904	2904	2904	2904	2904	2906	2908	2906	2908	2925	1734
	Tension	lbs.	1,780	2,930	4,340	5,950	7,950	10,190	12,660	18,700	25,870	33,940	44,240	56,000
		kN	7.9	13	19.3	26.5	35.4	45.3	56.3	83.1	115	151	196	249
Grade BC ASTM-A354	Torque	ft.-lbs.	10	20	35	56	86	138	173	306	495	742	1,090	1,530
		Nm	13.6	27.1	47.5	75.9	117	187	234	415	671	1,006	1,478	2,075
	Impactool Recommended		2902	2902	2903	2906	2906	2906	2908	2925	2934	2934	2940	2945
			2904	2904	2904	2904	2904	2904	2906	2906	2925	2925	1734	
	Tension	lbs.	2,340	3,850	5,700	7,815	10,430	13,380	16,610	24,550	33,960	44,550	58,070	73,500
		kN	10.4	17.1	25.3	34.8	46.4	59.5	74	109	151	198	258	327
Grade 8 ASTM-A354	Torque	ft.-lbs.	11	23	40	65	99	159	198	350	566	848	1,245	1,750
		Nm	14.9	31.2	54.2	88.1	134	216	268	475	767	1,150	1,688	2,373
Grade BD	Impactool Recommended		2902	2902	2903	2903	2906	2906	2908	2925	2934	2934	2940	2950
			2904	2904	2904	2904	2904	2904	2904	2906	2906	2925	1734	
	Tension	lbs.	2,740	4,400	6,510	8,930	11,920	15,290	18,980	28,050	38,800	50,900	66,360	84,000
		kN	12.2	19.6	28.9	39.7	53	68	84.4	125	172	226	295	374
ASTM-A490	Torque	ft.-lbs.							250	435	715	1,070	1,580	2,125
		Nm							339	590	970	1,451	2,142	2,882
	Impactool Recommended								2925	2934	2934	2940	2945	2950
										2925	1734			
	Tension	lbs.							24,000	35,000	49,000	64,000	80,000	102,000
		kN							107	156	218	285	356	454

Only certain Impacttools are shown in this chart. Compare the required torque shown in this chart with torque range figures shown in the Impacttool specifications tables to select other suitable tools.

Bolt Grade	Bolt Diameter, in.		1 ³ / ₈	1 ¹ / ₂	1 ⁵ / ₈	1 ³ / ₄	2	2 ¹ / ₄	2 ¹ / ₂	2 ³ / ₄	3	3 ¹ / ₄	3 ¹ / ₂	3 ³ / ₄	4
	Bolt Diameter, mm		35	38	41	44	51	57	64	70	76	83	89	95	102
	Hex Size, Inches		Max. 2 ³ / ₁₆	2 ³ / ₈	2 ⁹ / ₁₆	2 ³ / ₄	3 ¹ / ₈	3 ³ / ₈	3 ⁷ / ₈	4 ¹ / ₄	4 ⁵ / ₈	5	5 ³ / ₈	5 ³ / ₄	6 ¹ / ₈
	Min.		2 ¹ / ₈	2 ¹ / ₄	2 ⁷ / ₁₆	2 ⁵ / ₈	3	3 ¹ / ₂	3 ³ / ₄	4 ¹ / ₈	4 ¹ / ₂	4 ⁷ / ₈	5 ¹ / ₄	5 ⁵ / ₈	6
Grade 1	Torque	ft.-lbs.	660	860											
		Nm	895	1,166											
	Impacttool Recommended		2934	2940											
			1734												
	Tension	lbs.	28,400	34,600											
		kN	126	154											
Grade 5	Torque	ft.-lbs.	1,470	1,950											
		Nm	1,933	2,644											
	Impacttool Recommended		2945	2950											
	Tension	lbs.	64,000	77,000											
		kN	285	342											
ASTM-A325	Torque	ft.-lbs.	1,960	2,600											
		Nm	2,658	3,526											
	Impacttool Recommended		2950	5980	These bolts are used on structural steel applications. Torque and tension values are based on running the nut beyond the proof load of the bolt by the turn of the nut method. For detailed information consult the bolt manufacturer.										
	Tension	lbs.	85,000	103,000											
		kN	378	458											
Grade BB ASTM-A354	Torque	ft.-lbs.	1,580	2,080	2,700	3,400	5,150	7,500	10,300	13,100	17,100	21,800	27,500	34,000	41,300
		Nm	2,142	2,820	3,661	4,610	6,983	10,170	13,967	17,764	23,188	29,561	37,290	46,104	56,003
	Impacttool Recommended		2945	2950	5980	5980	5982	5982	588	588	588	599	599	599	599
	Tension	lbs.	69,050	83,550	99,680	116,480	155,120	199,360	248,640	285,080	341,780	403,725	470,400	542,850	620,025
		kN	307	371	443	518	690	887	1,106	1,268	1,520	1,796	2,092	2,414	2,758
Grade BC ASTM-A354	Torque	ft.-lbs.	2,075	2,440	3,545	4,465	6,785	9,815	13,600	16,550	21,645	27,700	34,760	42,980	52,360
		Nm	2,814	3,309	4,807	6,054	9,200	13,309	18,442	22,442	29,351	37,561	47,134	58,281	71,000
	Impacttool Recommended		2950	5980	5980	5980	5982	5982	588	588	588	599	599	599	599
	Tension	lbs.	90,630	109,620	130,830	152,880	203,950	261,660	326,340	361,100	432,910	517,690	595,840	687,610	787,370
		kN	403	488	582	680	907	1,164	1,452	1,606	1,926	2,303	2,650	3,058	3,493
Grade 8 ASTM-A354	Torque	ft.-lbs.	2,375	3,135											
		Nm	3,220	4,251											
Grade BD	Impacttool Recommended		2950	5980											
	Tension	lbs.	103,570	125,330											
		kN	461	557											
ASTM-A490	Torque	ft.-lbs.	2,780	3,700											
		Nm	3,770	5,017											
	Impacttool Recommended		5980	5980	These bolts are used on structural steel applications. Torque and tension values are based on running the nut beyond the proof load of the bolt by the turn of the nut method. For detailed information consult the bolt manufacturer.										
	Tension	lbs.	121,000	148,000											
		kN	538	658											

Torque Control Impacttools

IR Torque Control Impacttools are designed for applications requiring fastener tightening control. The tools shut off automatically when preset torque levels are reached. Depending upon the model, built-in or detachable torsion bars sense torque levels, and signal a mechanical shut-off device to prevent over-torquing. These tools combine a ball and cam impact mechanism with a heavy-walled aluminum hammer case for maximum strength, minimum weight.



Torque Range: 6-90 ft.-lb., 8-122 Nm

Torque Control Impacttools



● 5020TAL1



★ 5040TDQ

Equipment at Extra Price Series 5020T and Model 5020TDQ

- Torque setting clamp No. 5020T-951 (for Series 5020T only)
- Horizontal hanger:
 - One horizontal hanger No. 5020-366 – includes spacers & screws
 - Two horizontal hanger spacers No. 504-140
 - Two horizontal hanger cap screws No. 504-376A
- Vertical hanger No. 5020-365

Series 5040T and Model 5040TDQ

- Vise-type torque setting jig No. 5040T-A951 (for Series 5040T only)
- Horizontal hanger:
 - One horizontal hanger No. 5040-366. Includes the following; Two horizontal hanger spacers No. 504-140 and two horizontal hanger cap screws No. 504-376A
- Vertical hanger No. 5040-365



▲ 5040TAL1

Model	Drive Description	Torque Range		Type Torsion Bar	Free Speed rpm	Impacts per minute	Weight		Length		Side to Center Distance		CFM
		ft.-lb.	Nm				lb.	kg	in.	mm	in.	mm	
● 5020TAL1	3/8" square	6-17	8-23	AB	1400	2100	4	1.81	9	229	1 1/16	27	10
5020TAH1	3/8" square	10-30	13-40	AB	1400	2100	4	1.81	9	229	1 1/16	27	10
5020TDQ	7/16" hex Q.C.	10-30	13-40	NAD	1400	2100	4 3/16	1.9	11	279	1 1/16	27	10
▲ 5040TAL1	1/2" square	20-45	27-61	AB	1500	2150	6 1/4	2.84	10 1/2	267	1 3/8	35	15
5040TAM1	1/2" square	40-65	54-88	AB	1500	2150	6 1/4	2.84	10 1/2	267	1 3/8	35	15
5040TAH1	1/2" square	60-90	81-122	AB	1500	2150	6 1/4	2.84	10 1/2	267	1 3/8	35	15
★ 5040TDQ	7/16" hex Q.C.	20-90	27-122	NAD	1500	2150	6 7/8	3.12	13 3/4	349	1 3/8	35	15

All of the above square drive Impacttools are furnished with pin-type retainer.

Series 5020 and 5040 Impacttools have 1/4" NPT air inlet: 1/4" (6 mm) size hose is recommended.

Performance figures are at 90 psi (620 kPa) air pressure.

AB = Adjustable, Built-in torsion bar. NAD = Non-adjustable, Detachable torsion bar.

Weights shown are with torsion bar, less socket. Weights of models with detachable torsion bars are with heaviest torsion bars. Lengths shown are with torsion bar, less socket.

Models ending in L1 are equipped with light torsion bar.

Models ending in M1 are equipped with medium torsion bar.

Models ending in H1 are equipped with heavy torsion bar.

Torque Control Impacttools

Non-adjustable Detachable Torsion Bars and Kits for Models 5020TDQ and 5040TDQ

• No. 5040TDQ–KP637 torsion bar kit (consists of one each non-adjustable torsion bar with pin-type retainer and No. 5040TDQ–637 torsion bar case)

• No. 5040TDQ–KB637 torsion bar kit (consists of one each non-adjustable torsion bar with ball-type retainer and No. 5040TDQ–637 torsion bar case)

Torsion Bar Number		Model 5020TDQ		Model 5040TDQ		Color Code
With 1/2" Square Drive Pin-Type Retainer	With 1/2" Square Drive Ball-Type Retainer	Torque Range ft.-lb.	Torque Range Nm	Torque Range ft.-lb.	Torque Range Nm	
5040TDQ–P535–1	5040TDQ–B535–1	6-10	8.14-13.6	20-25	27.1-33.9	Red
5040TDQ–P535–2	5040TDQ–B535–2	8-12	10.8-16.3	22-30	29.8-40.7	Orange
5040TDQ–P535–3	5040TDQ–B535–3	10-14	13.6-19	25-35	33.9-47.5	Yellow
5040TDQ–P535–4	5040TDQ–B535–4	12-16	16.3-21.7	30-40	40.7-54.2	Green
5040TDQ–P535–5	5040TDQ–B535–5	14-18	19-24.4	35-45	47.5-61.0	Blue
5040TDQ–P535–6	5040TDQ–B535–6	16-20	16.3-27.1	40-50	54.2-67.8	Violet
5040TDQ–P535–7	5040TDQ–B535–7	18-22	24.4-29.8	45-55	61.0-74.6	Red
5040TDQ–P535–8	5040TDQ–B535–8	20-24	27.1-32.5	50-60	67.8-81.4	Orange
5040TDQ–P535–9	5040TDQ–B535–9	22-26	29.8-35.2	55-65	74.6-88.1	Yellow
5040TDQ–P535–10	5040TDQ–B535–10	24-28	32.5-38	60-75	81.3-101	Green
5040TDQ–P535–11	5040TDQ–B535–11	26-29	35.2-39.3	70-85	94.9-115	Violet
5040TDQ–P535–12	5040TDQ–B535–12	27-30	36.6-40.7	75-90	102-122	Blue

Torque Control Impactool Operation

The Torque Control Impactool converts the torque of the air motor into powerful rotary impacts when a certain resistance to turning is met. The Ingersoll-Rand principle of compressing a sturdy hammer spring and suddenly releasing this energy to strike a powerful rotary blow makes it possible to quickly and efficiently run fasteners.

The Torque Control Impactool also incorporates a torsion bar and an automatic shut-off valve. Torque control is obtained by preloading the torsion bar to the torque desired. When the resistance of the fastener being run becomes equal to the torque preloaded in the torsion bar, the extra clearance in the flutes of the locking collar allows the torsion bar to flex a few degrees beyond its original setting.

Acting like a spring, the torsion bar snaps back, supplying additional impetus to the hammer, causing the hammer to rebound higher and trip the automatic shut-off valve, instantly stopping the tool. By varying the setting of the torsion bar, using different torsion bars and/or different size tools, torques from 6 to 90 ft.-lbs. (8.14 to 122 Nm) can be accurately obtained time after time.

Ball and cam mechanism converts air motor torque into powerful rotary impacts.

Tough steel anvil transfers blows from impact hammer to the fastener.

Adjustable torsion bar signals shutoff device when preset torque is reached.

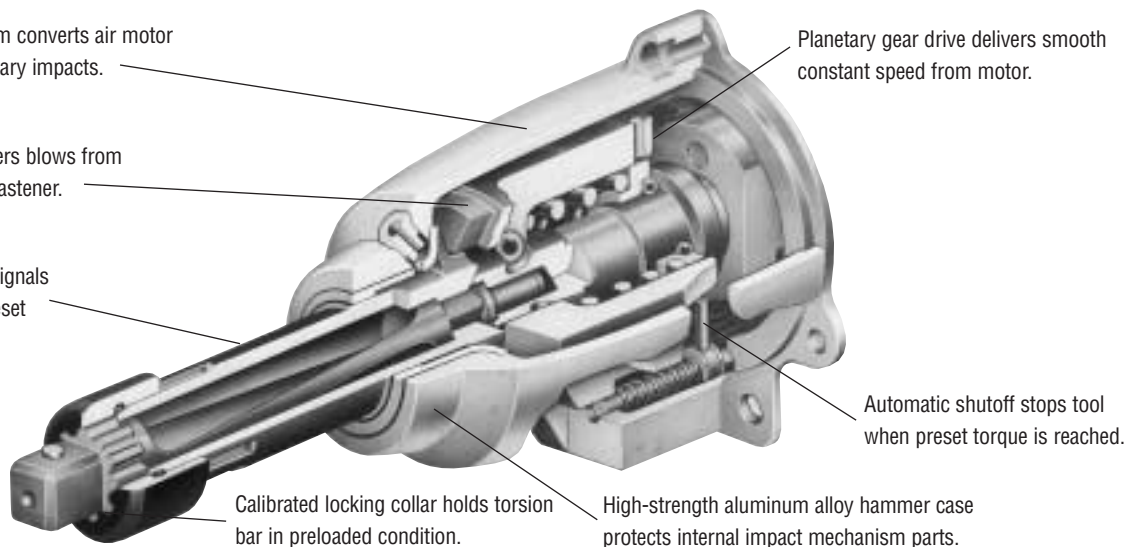

Planetary gear drive delivers smooth constant speed from motor.

Automatic shutoff stops tool when preset torque is reached.

Calibrated locking collar holds torsion bar in preloaded condition.

High-strength aluminum alloy hammer case protects internal impact mechanism parts.

Electric Impacttools



For applications where the use of compressed air is not practical, IR offers a complete line of electric Impacttools in 3/8, 1/2, 3/4 and 1-inch drive sizes. All models are ranked according to the Super Duty/Heavy Duty/Standard Duty ratings, and incorporate the same high quality of design and construction that has made Ingersoll-Rand the world leader in Impacttools.

Electric Impacttools



● 8005



▲ 8055



★ 8056

Features

- Full ball bearing construction throughout for maximum performance
- High quality, heat treated steel gears for longer life
- Full power in reverse for removing bolts, nuts, studs and lag screws
- Lightweight cast aluminum housing and handle reduce operator fatigue
- Heavy duty 3-conductor cord – grounding required
- Delivers high torque for maximum efficiency

Model	Drive Description	Handle	Free Speed rpm	Impacts per minute	Maximum Torque		Recomm. Torque Range		Weight, less socket lb.	Length, less socket in.	Side to Center Distance in.	amps	volts	Chord Length
					ft.-lb.	Nm	ft.-lb.	Nm						
●8005	3/8" square	Pistol	2000	2200	85	115	5-50	7-68	4 1/2	10 1/8	1 3/8	3.0	120 AC	10'
8049	1/2" square	Pistol	1900	2000	290	393	30-180	41-244	6 3/4	11 11/16	1 5/8	5.0	120 AC	10'
8053	1/2" square	Pistol	1900	1900	330	448	50-225	68-305	7	10 1/4	1 5/8	5.0	120 AC/DC	15'
8053QC	7/16" hex QC	Pistol	1900	1900	300	407	50-200	68-272	7	11	1 5/8	5.0	120 AC/DC	15'
▲ 8055	3/4" square	Pistol	1700	1725	450	610	100-375	136-509	10	11 7/8	1 3/4	7.5	120 AC/DC	8'
8062	5/8" hex QC	Pistol	1700	1725	400	542	100-350	136-475	10	12 7/8	1 3/4	7.5	120 AC/DC	8'
★8056	1" square	Grip	800	900	750	1017	300-600	407-814	32 1/2	14 1/8	2 3/8	10.0	120 AC/DC	15'

Tools comply with OSHA requirements and are UL listed.

Quick Reference Guide

Drive Size	Super Duty		Heavy Duty		Standard Duty		Torque Control		Electric	
	Series	Page	Series	Page	Series	Page	Series	Page	Series	Page
3/8"	2902	5	1702	5			5020	19	8005	22
3/8"	2903	5	2904	5						
7/16" Quick Change					2131	6	5020	19		
7/16" Quick Change							5040	19		
1/2"	2906	6	2707	6	2705	6	5040	19	8053	22
1/2"					2904	6			8049	22
1/2"					2131	6				
5/8"	2908	8								
5/8" Quick Change									8062	22
3/4"	2925	10	1720	10					8055	22
3/4"			2161P	10						
1"	2934	12	1734	12	1720	10			8056	22
1"	2940	13	1712	12	2171P	10				
1 1/2"	2945	14								
1 1/2"	2950	14								
1 1/2"	5980	14								
2 1/2"	5982	15								
2 1/2"	588	15								
3 1/2"	599	15								

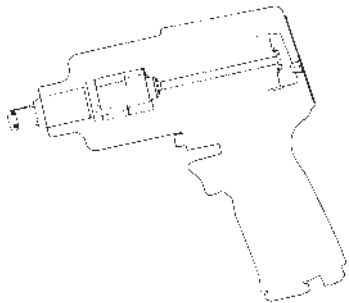

Pressure-Feed Lubrication System

Ingersoll-Rand uses a "pressure-feed" lubrication system on all Twin-Hammer and Jumbo Hammer Impact Mechanisms. This exclusive system allows the operator to externally inject grease into a chamber through a grease fitting in the rear of the motor housing.

Air pressure from the motor force feeds the right amount of grease from the

chamber and through the rotor, distributing a film of protective grease on the hammer mechanism. This system insures the continuous lubrication of critical hammer parts, resulting in longer, trouble-free life. Use Cat. No. R000A2-228 Metal Grease Gun and Cat. No. 100 Grease, or equivalent. This grease has the right viscosity to flow through the small orifice in the rotor and anvil.

Power Regulator System

Some Twin-Hammer and Jumbo Hammer tools are equipped with a combination power regulator/reverse valve. This design allows operators to adjust power output, to prevent over-torquing on delicate work, in one direction—while maintaining full power in the opposite direction. The power output in either direction is designated by the numbers "0" thru "5". Number 5 designates maximum power.

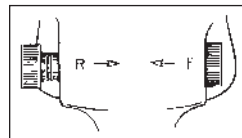

Forward:

Regulator on 3 reduces power output. Switching to **reverse** automatically maintains full power.

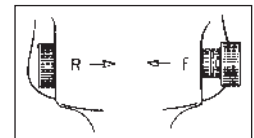

Reverse:

Regulator on 3 reduces power output. Switching to **forward** automatically maintains full power.

Regulator on 5:

Forward, maximum power output
Reverse, maximum power output

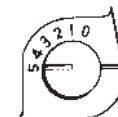

Sockets and Accessories

The next several pages cover Impactool sockets and accessories, excerpted from the Ingersoll-Rand IRAX Accessories catalog (Form # 52225-F). These items are specifically designed to maximize the performance and versatility of your Impactools.

The selection presented here includes:

- Socket sets
- Power angle attachments
- Power driver extensions
- Power hex to square adapters
- Power socket adapters
- Individual sockets
- “O” rings and retaining pins
- One-piece socket retainers
- Power universal joints
- Power keyless chucks
- Power quick change chucks



Sockets and Accessories

Socket Sets

Part Number	Description
72313	3/8" drive set (5/16, 3/8, 7/16, 1/2, 9/16, 5/8, 11/16, 3/4, metal tray)
77314	3/8" drive deep set (5/16, 3/8, 7/16, 1/2, 9/16, 5/8, 11/16, 3/4, metal tray)
72356M	3/8" drive metric set (8, 9, 10, 11, 12, 13, 14, 15, 16, 17, 18, 19, metal tray)
77357M	3/8" drive deep metric set (8, 9, 10, 11, 12, 13, 14, 15, 16, 17, 18, 19, metal tray)
74411	1/2" drive set (7/16, 1/2, 9/16, 5/8, 11/16, 3/4, 13/16, 7/8, 15/16, 1, 11/16, metal tray)
73412	1/2" drive deep set (3/8, 7/16, 1/2, 9/16, 5/8, 11/16, 3/4, 13/16, 7/8, 15/16, 1, metal tray)
74466M	1/2" drive metric set (10, 11, 12, 13, 14, 15, 16, 17, 18, 19, 20, 21, 22, 23, 24, 27, metal tray)
73467M	1/2" drive deep metric set (10, 11, 12, 13, 14, 15, 16, 17, 18, 19, 20, 21, 22, 23, 24, 27, metal tray)
075608L	3/4" drive deep set (7/8, 15/16, 1, 11/16, 11/8, 11/4, 15/16, 11/2)
075609	3/4" drive set (3/4, 13/16, 7/8, 15/16, 1, 11/16, 11/8, 13/16, 11/4, metal tray)
075610	3/4" drive set (3/4, 13/16, 7/8, 15/16, 1, 11/16, 11/8, 13/16, 11/4, 15/16, 13/8, 17/16, 11/2)

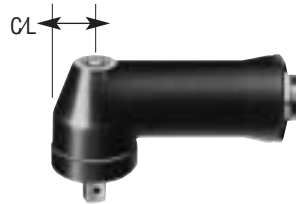

Power Angle Attachments

A reduction of approximately 50% of the torque output will be encountered.

Part Number	Square Drive Size in.	Length in.	Height Over Drive, in.	Amount of Angle, Degrees	Weight/Lbs.	C/L
4UA9 ⁽¹⁾	1/2	6 1/4	2 5/16	90	3.0	1 3/32
2920A90	3/4	7	3 1/2	90	8.6	1 23/64
2934A90	1	8 1/2	4 3/8	90	16	1 27/32

⁽¹⁾ Angle Head gear ratio 1.333 to 1-Fits any 1/2 Drive Impact



Power Hex to Square Adapters

Part Number	Drive Size in.		Length in.	Major Diam. in.
	Hex	Square		
7102	1/4	1/4	2	3/8
7106	1/4	3/8	4	9/16
7121	7/16	1/2	2 3/4	2 1/32



Power Socket Adapters

Part Number	Square Drive Size in.		Length in.	Major Diam. in.
	Female	Male		
2U-215	3/8	1/2	1 5/16	5/8
07655	3/4	1	2 1/4	1 5/8
07656	1	3/4	1 7/8	2 1/8
25006	2 1/2	1 1/2	4 1/2	5

Part Number	Spline Drive		Length in.	Major Diam. in.
	Female	Male		
09902	No.5 Spline	1" Sq.	4 3/8	2 3/8
10005	1" Sq.	No.5 Spline	4 1/4	2 1/4



Power Driver Extensions

Part Number	Square Drive Size in.	Length in.
7175P	3/8	3
7181P	1/2	5
07567	3/4	7
10607	1	7
15097P	1 1/2	8
25001-10	2 1/2	10

Part Number	Spline Drive No.	Length in.
09901-15	5	15

Sockets and Accessories

3/8" Square Drive Power Sockets

Wrench Size in.	Part Number	Bolt Depth in.
Standard – Hex/6 Point		
5/16	7210H	1/2
11/32	7211H	1/2
3/8	7212H	1/2
7/16	7214H	1/2
1/2	7216H	1/2
9/16	7218H	1/2
5/8	7220H	1/2
11/16	7222H	9/16
3/4	7224H	9/16
Deep – Hex/6 Point		
5/16	7710H	1
3/8	7712H	1
7/16	7714H	1
1/2	7716H	1
9/16	7718H	1
5/8	7720H	1
11/16	7722H	1
3/4	7724H	1
Ball Type Universal – Hex/6 Point		
3/8	7273P	1/2
7/16	7274P	1/2
1/2	7275P	9/16
9/16	7276P	9/16

Metric–1/2" Square Drive Power Sockets

Wrench Size mm	Part Number
Standard – Metric/6 Point	
8	7408M
9	7409M
10	7410M
11	7411M
12	7412M
13	7413M
14	7414M
15	7415M
16	7416M
17	7417M
18	7418M
19	7419M
21	7421M
22	7422M
23	7423M
24	7424M
25	7425M
26	7426M
27	7427M
28	7428M
30	7430M
32	7432M

1/2" Square Drive Power Sockets

Wrench Size in.	Part Number	Bolt Depth in.
Standard – Hex/6 Point		
3/8	7412H	7/8
7/16	7414H	7/8
1/2	7416H	7/8
9/16	7418H	7/8
5/8	7420H	7/8
11/16	7422H	7/8
3/4	7424H	7/8
13/16	7426H	7/8
7/8	7428H	7/8
15/16	7430H	1 1/8
1	7432H	1 1/8
1 1/16	7434H	1 1/8
1 1/8	7436H	1 1/8
1 1/4	7440H	1 1/8
Deep – Hex/6 Point		
3/8	7312H	2 5/8
7/16	7314H	2 5/8
1/2	7316H	2 5/8
9/16	7318H	2 5/8
5/8	7320H	2 5/8
11/16	7322H	2 9/16
3/4	7324H	2 9/16
13/16	7326H	2 9/16
7/8	7328H	2 3/4
15/16	7330H	2 3/4
1	7332H	2 11/16
1 1/16	7334H	2 11/16
1 1/8	7336H	2 11/16
Ball Type Universal – Hex/6 Point		
7/16	7474P	3/8
1/2	7475P	3/8
9/16	7476P	9/16
5/8	7477P	5/8
3/4	7479P	1 1/16
13/16	7480P	1 1/16

3/4" Square Drive

Wrench Size in.	Part Number	Bolt Depth in.
Standard – Hex/6 Point		
9/16	07509	3/4
3/4	07512	15/16
13/16	07513	15/16
7/8	07514	1
15/16	07515	1
1	07516	1 1/16
1 1/16	07517	1 1/16
1 1/8	07518	1 1/16
1 3/16	07519	1 1/8
1 1/4	07520	1 1/8
1 5/16	07521	1 1/8
1 3/8	07522	1 1/8
1 7/16	07523	1 5/32
1 1/2	07524	1 5/32
Deep – Hex/6 Point		
3/4	07512L	1 5/8
13/16	07513L	1 5/8
7/8	07514L	1 5/8
15/16	07515L	1 5/8
1	07516L	2
1 1/16	07517L	2
1 1/8	07518L	2
1 3/16	07519L	2 3/16
1 1/4	07520L	2 3/16
1 5/16	07521L	2 3/16
1 3/8	07522L	2 5/16
1 7/16	07523L	2 3/8
1 1/2	07524L	2 3/8

1" Square Drive

Wrench Size in.	Part Number	Bolt Depth in.
Standard – Hex/6 Point		
3/4	10012	1 1/8
13/16	10013	1 1/8
7/8	10014	1 1/8
15/16	10015	1 1/8
1	10016	1 1/4
1 1/16	10017	1 1/4
1 1/8	10018	1 1/4
1 3/16	10019	1 1/4
1 1/4	10020	1 3/8
1 5/16	10021	1 7/16
1 3/8	10022	1 1/2
1 7/16	10023	1 1/2
1 1/2	10024	1 9/16
1 9/16	10025	1 5/8
1 5/8	10026	1 11/16
1 11/16	10027	1 3/4
1 3/4	10028	1 13/16
1 13/16	10029	1 7/8
1 7/8	10030	1 15/16
1 15/16	10031	2
2	10032	2 1/16
2 1/16	10033	2 1/8
2 1/8	10034	2 3/16
2 3/16	10035	2 1/4
2 1/4	10036	2 5/16
2 5/16	10037	2 3/16
2 3/8	10038	2 1/4
2 7/16	10039	2 3/8
2 1/2	10040	2 1/2
2 9/16	10041	2 1/2
2 5/8	10042	2 1/2
2 11/16	10043	2 3/4
2 3/4	10044	2 3/4
2 13/16	10045	2 3/4
2 7/8	10046	2 3/4
2 15/16	10047	3
3	10048	3
3 1/8	10050	3 1/8
3 3/8	10054	3
3 1/2	10056	3

1" Square Drive (cont.)

Wrench Size in.	Part Number	Bolt Depth in.
Deep – Hex/6 Point		
1 15/16	10021L	2 3/8
1 1/2	10024L	2 3/8
1 5/8	10026L	2 7/8
Thin Wall Deep – Hex/6 Point		
1 1/16	10017-LT	3 1/8
1 1/4	10020-LT	3 1/8

Sockets and Accessories

1½" Square Drive

Wrench Size in.	Part Number	Bolt Depth in.
Standard – Hex/6 Point		
1 ³ / ₈	15022	2 ¹ / ₈
1 ⁷ / ₁₆	15023	2 ¹ / ₈
1 ¹ / ₂	15024	2 ¹ / ₈
1 ⁹ / ₁₆	15025	2 ¹ / ₈
1 ⁵ / ₈	15026	2 ¹ / ₈
1 ¹¹ / ₁₆	15027	2 ¹ / ₈
1 ³ / ₄	15028	2 ¹ / ₈
1 ¹³ / ₁₆	15029	2 ¹ / ₈
1 ⁷ / ₈	15030	2 ¹ / ₈
1 ¹⁵ / ₁₆	15031	2 ¹ / ₈
2	15032	2 ¹ / ₈
2 ¹ / ₁₆	15033	2 ¹ / ₈
2 ¹ / ₈	15034	2 ¹ / ₈
2 ³ / ₁₆	15035	2 ¹ / ₈
2 ¹ / ₄	15036	2 ⁵ / ₈
2 ⁵ / ₁₆	15037	2 ⁵ / ₈
2 ³ / ₈	15038	2 ⁵ / ₈
2 ⁷ / ₁₆	15039	2 ⁵ / ₈
2 ¹ / ₂	15040	2 ⁵ / ₈
2 ⁹ / ₁₆	15041	2 ⁵ / ₈
2 ⁵ / ₈	15042	2 ³ / ₄
2 ¹¹ / ₁₆	15043	2 ³ / ₄
2 ³ / ₄	15044	2 ⁷ / ₈
2 ¹³ / ₁₆	15045	2 ⁷ / ₈
2 ⁷ / ₈	15046	3 ¹ / ₈
2 ¹⁵ / ₁₆	15047	3 ¹ / ₈
3	15048	3 ¹ / ₈
3 ¹ / ₈	15050	3 ³ / ₈
3 ³ / ₁₆	15051	3 ³ / ₈
3 ¹ / ₄	15052	3 ¹ / ₂
3 ⁵ / ₁₆	15053	3 ¹ / ₂
3 ³ / ₈	15054	3 ¹ / ₂
3 ⁷ / ₁₆	15055	3 ³ / ₄
3 ¹ / ₂	15056	3 ³ / ₄
3 ⁹ / ₁₆	15057	3 ³ / ₄
3 ⁵ / ₈	15058	3 ³ / ₄
3 ¹¹ / ₁₆	15059	3 ³ / ₄
3 ³ / ₄	15060	3 ³ / ₄

1½" Square Drive (cont.)

Wrench Size in.	Part Number	Bolt Depth in.
Standard – Hex/6 Point		
3 ⁷ / ₈	15062	3 ³ / ₄
3 ¹⁵ / ₁₆	15063	3 ³ / ₄
4	15064	3 ¹ / ₂
4 ¹ / ₈	15066T	3 ³ / ₄
4 ³ / ₁₆	15067	3 ³ / ₄
4 ¹ / ₄	15068	3 ³ / ₄
4 ⁵ / ₁₆	15069	4 ¹ / ₈
4 ¹ / ₂	15072	4
4 ⁵ / ₈	15074	4
4 ³ / ₄	15076	4
Deep – Hex/6 Point		
1 ³ / ₈	15022L	3 ¹ / ₄
1 ⁷ / ₁₆	15023L	3 ¹ / ₄
1 ¹ / ₂	15024L	3 ¹ / ₄
1 ⁹ / ₁₆	15025L	3 ¹ / ₄
1 ⁵ / ₈	15026L	3 ¹ / ₄
1 ¹¹ / ₁₆	15027L	3 ¹ / ₄
1 ³ / ₄	15028L	3 ¹ / ₄
1 ¹³ / ₁₆	15029L	3 ¹ / ₄
1 ⁷ / ₈	15030L	3 ¹ / ₄
1 ¹⁵ / ₁₆	15031L	3 ¹ / ₄
2	15032L	3 ¹ / ₄
2 ¹ / ₁₆	15033L	3 ¹ / ₄
2 ¹ / ₈	15034L	3 ¹ / ₄
2 ³ / ₁₆	15035L	3 ¹ / ₄
2 ¹ / ₄	15036L	3 ⁵ / ₈
2 ⁵ / ₁₆	15037L	3 ⁵ / ₈
2 ³ / ₈	15038L	3 ⁵ / ₈
2 ⁷ / ₁₆	15039L	3 ⁵ / ₈
2 ¹ / ₂	15040L	3 ⁵ / ₈
2 ⁹ / ₁₆	15041L	3 ⁵ / ₈
2 ⁵ / ₈	15042L	3 ⁷ / ₈
2 ¹¹ / ₁₆	15043L	3 ⁷ / ₈
2 ³ / ₄	15044L	3 ⁷ / ₈
2 ¹³ / ₁₆	15045L	4 ¹ / ₂
2 ⁷ / ₈	15046L	4 ¹ / ₂
3	15048L	4 ³ / ₄
3 ¹ / ₁₆	15049L	4 ³ / ₄

1½" Square Drive (cont.)

Wrench Size in.	Part Number	Bolt Depth in.
Deep – Hex/6 Point		
3 ¹ / ₈	15050L	4 ³ / ₄
3 ³ / ₁₆	15051L	4 ⁷ / ₈
3 ¹ / ₄	15052L	4 ⁷ / ₈
3 ⁵ / ₁₆	15053L	4 ⁷ / ₈
3 ⁷ / ₁₆	15055L	4 ⁷ / ₈
3 ¹ / ₂	15056L	4 ⁷ / ₈
3 ⁹ / ₁₆	15057L	5 ¹ / ₈
3 ⁵ / ₈	15058L	5 ¹ / ₈
3 ¹¹ / ₁₆	15059L	5 ¹ / ₈
3 ³ / ₄	15060L	5 ¹ / ₈
3 ¹³ / ₁₆	15061L	5 ¹ / ₈
3 ⁷ / ₈	15062L	5 ¹ / ₈
4 ¹ / ₂	15072L	5 ⁵ / ₈
4 ⁵ / ₈	15074L	5 ⁷ / ₈

2½" Square Drive

Wrench Size in.	Part Number	Bolt Depth in.
Standard – Hex/6 Point		
1¾	25028	2 ¹⁵ / ₁₆
1 ⁷ / ₈	25030	2 ¹⁵ / ₁₆
2	25032	2 ¹⁵ / ₁₆
2 ¹ / ₈	25034	2 ¹⁵ / ₁₆
2 ¹ / ₄	25036	2 ¹⁵ / ₁₆
2 ³ / ₈	25038	2 ¹⁵ / ₁₆
2 ⁵ / ₈	25042	2 ¹⁵ / ₁₆
2 ³ / ₄	25044	2 ¹⁵ / ₁₆
2 ¹⁵ / ₁₆	25047	2 ¹⁵ / ₁₆
3	25048	2 ¹⁵ / ₁₆
3 ¹ / ₈	25050	3 ¹⁵ / ₃₂
3 ¹ / ₄	25052	3 ¹⁵ / ₃₂
3 ³ / ₈	25054	3 ¹⁵ / ₃₂
3 ¹ / ₂	25056	3 ¹⁵ / ₃₂
3 ⁵ / ₈	25058	3 ¹⁵ / ₃₂
3 ³ / ₄	25060	3 ³ / ₄
3 ⁷ / ₈	25062	3 ³ / ₄
4	25064	3 ³ / ₄
4 ¹ / ₈	25066	3 ³ / ₄
4 ¹ / ₄	25068	4 ⁷ / ₃₂
4 ³ / ₈	25070	4 ⁷ / ₃₂
4 ¹ / ₂	25072	4 ³ / ₄
4 ⁵ / ₈	25074	4 ³ / ₄
4 ⁷ / ₈	25078	4 ³ / ₄
5	25080	4 ³ / ₄
5 ¹ / ₈	25082	4 ³ / ₄
5 ¹ / ₄	25084	4 ³ / ₄
5 ³ / ₈	25086	5 ¹ / ₃₂
5 ¹ / ₂	25088	5 ¹ / ₃₂
5 ⁵ / ₈	25090	5 ¹⁵ / ₃₂
6 ¹ / ₄	25100	5

No. 5 Spline Drive⁽¹⁾

Wrench Size in.	Part Number	Bolt Depth in.
Standard – Hex/6 Point		
7/8	09914	1½
1 ¹ / ₁₆	09917	1½
1 ³ / ₁₆	09919	1½
1 ¹ / ₄	09920	1½
1 ⁷ / ₁₆	09923	1 ⁵ / ₈
1½	09924	1 ⁵ / ₈
1 ⁵ / ₈	09926	1 ³ / ₄
2	09932	2 ¹ / ₈

⁽¹⁾ 14 Spline, 1⁵/_{8"} Diameter

"O" Rings and Retaining Pins

Part Number	Description
For 2½" Square Drive Sockets	
588-216	4 ¹ / _{8"} I.D. "O" Ring
588-215	4 ⁵ / _{8"} X 5 ¹ / _{16"} Retaining Pin
For 3½" Square Drive Sockets	
599-216	6 ¹ / _{4"} I.D. "O" Ring
599-215	6 ¹ / _{2"} X 1 ¹ / _{2"} Retaining Pin

Sockets and Accessories

One Piece Socket Retainers

Warning: One Piece Socket Retainers should not be used for any purpose other than to retain sockets on Impacttools. Always check for wear on pin before using. Refer to the instructions furnished with the Retainer for selection of correct sizes and installation procedure.



Part Number	Inside Diameter in.	mm
For 3/4" Square Drive Sockets		
RR10005S	1 1/4	32
RR10032S	1 7/16	37
RR10034S	1 5/8	41
For 1" Square Drive Sockets		
RR10008S	1 3/4	45
RR10010S	1 15/16	49
RR10015S	2 1/8-2 1/4	54-57
RR10017S	2 1/2	64
RR10019S	2 5/8	67
RR10020S	2 7/8-3	73-76
For 1 1/2" Square Drive Sockets		
RR10020S	2 7/8-3	73-76
RR10025S	3 3/8	86
RR10030S	3 7/8	98
RR10035S	4 3/8	111



Power Universal Joints

Universal joints make it easy to work around difficult angles and hard-to-reach nuts.

Driver	Part Number	Depth in.	Major Diam. in.
3/8" Sq.	7270P	2 1/2	1 5/16
1/2" Sq.	7470P	2 1/2	1 1/8
3/4" Sq.	07570	4 1/4	1 3/4
1" Sq.	10670	4 5/16	2 3/8
No. 5 Spline	*09670A	8	2 7/8

*Availability subject to prior sale.



Power Quick Change Chuck

For greatest versatility on screw-driving jobs, snap a Quick Change Chuck on the drive of your Impacttool. A wide variety of hex shank bits can be easily inserted and quickly changed by merely pushing on the spring loaded collar.

Square Drive Size in. Female	Part Number	Hex Chuck Size in. Female
3/8	2U-A925-4	1/4
3/8	502-A925-7	7/16
1/2	4U-A925-7	7/16

Flush Hex Sockets

Socket Size	For Series 6 and 7 3D6 Angle Head Part No.	For Series 8 and 9 32 Angle Head Part No.	For Series 8 and 9 53 Angle Head Part No.	For Series 9 83 Angle Head Part No.
3/4"				182A88-807
13 mm	8SA34-807M	8SA34-807M	182A13MF-807	
17 mm			8SA56-807M	
19 mm				182A88-807

Protective Tool Boots

Keep your Ingersoll-Rand air impact ratchets, wrenches, and drills free from external damage with protective boots. As you

work, these boots also absorb some of the tool vibration, keeping you more comfortable, too.



Tool Number	Boot Number	Material
1702P1	202-P32	Vinyl
1701B1	211-P32	Vinyl
2705A1	231-P32	Vinyl
2131, 2131-2	2131-P32	Vinyl
2707A1	244-P32	Vinyl
2925P1	2161-P32	Vinyl
2925P3	2161-P32	Vinyl
231, 231-2	230-32	Leather
261-P32	261-1710	Vinyl
2080-P32	2080	Vinyl

Balancers



E-Z Torque™ tool holders and Balance Air™ balancers

This unique combination of a fully adjustable tool holder and compact, efficient balancer provides a fast, easy way of achieving optimum tool positioning with proper operator ergonomics.

Constructed of cast aluminum and steel, with ball bearing rollers and a 48" travel, the E-Z Torque unit eliminates spring pull-back, and can be effectively used with air or electric tools, and can handle up to 100 ft.-lbs. of torque.

The 50 lb. capacity Balance Air unit has a capacity range of 2-50 lbs., with a floating action that eliminates tension on the load. An external regulator provides easy adjustment, and the unit can provide "stepped" operation by sequencing the air signal.

E-Z Torque and Balance Air – a productivity solution designed for the operator, and to maximize the performance of Ingersoll-Rand tools.

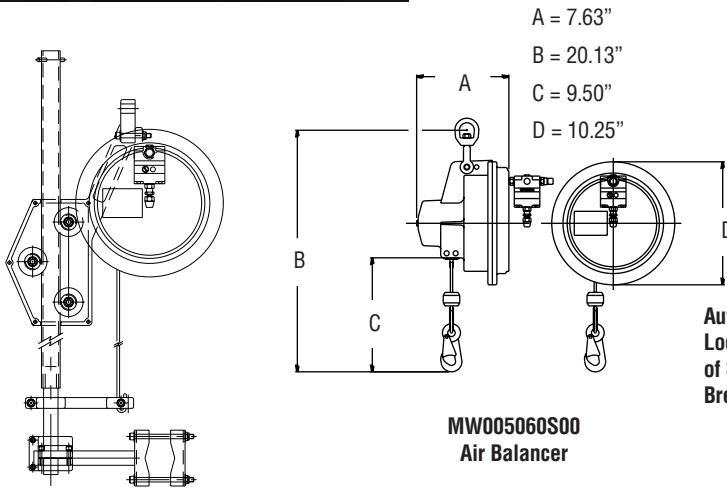

MW005060S00
Air Balancer

MT005060S00
E-Z Torque

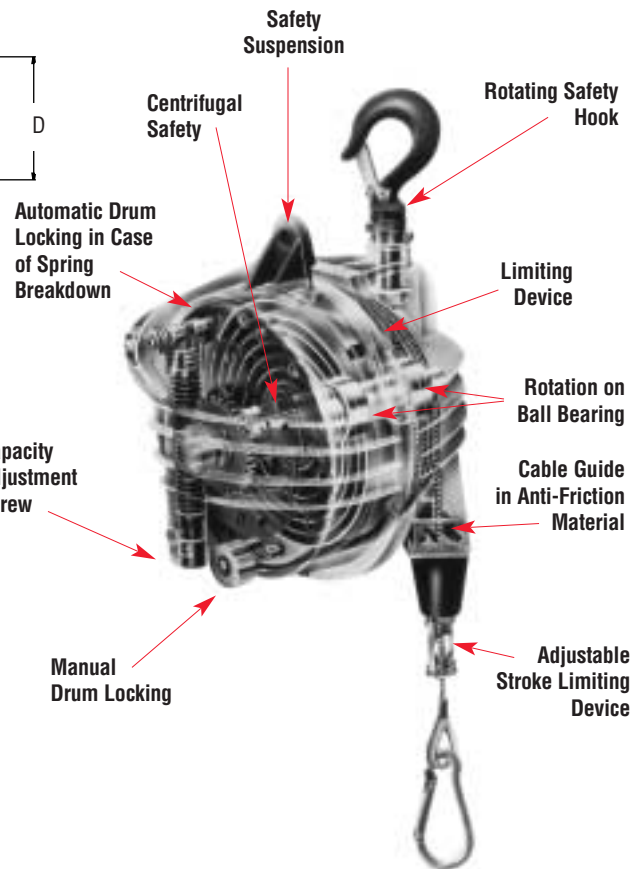

The IRAX red balancers from Ingersoll-Rand offer you five different series to fill all your balancing requirements. The light, medium, intermediate, heavy and super duty series cover weight balancing requirements from 1 lb. to 330 lbs.

These rugged balancers are made of die cast aluminum. A safety locking device on the medium, heavy and super duty models is designed to prevent dropping of the tool should the spring fail. Easy to use controls allow for accurate spring adjustment.

With over 50 models to choose from and lifts ranging from 5 to 9 feet, IRAX balancers fill your balancer requirements with quality from Ingersoll-Rand.

Model Number Key

B	M	D	L	L	10
Balancer	H = Heavy I = Intermediate L = Light M = Medium S = Super	Duty	L = Long Cable (8.2' or 9.85') S = Short Cable (6.5')	Locking Type	Upper Weight Capacity in Kilograms

Balancers

Hose Reel Balancer – Specification

Model No.	Hose Nipples	Capacity lb.	Lift ft.
BHR-8	1/4"	7/8 - 1 3/4	4 1/4
BHR-15	1/4"	1 1/2 - 3 1/3	4 1/4
BHR-25	1/4"	2 5/8 - 5 1/2	4 1/4

Light Duty – Capacity 0.9 to 66.6 lbs. (0.4 to 3 kg)

- Rotary hook
- Self lubricating bushings
- Adjustable capacity and stroke limiting device
- Auxiliary safety suspension

Model No.	Capacity		Weight		Lift	
	lb.	kg	lb.	net-kg	ft.	mm
BLD1	.9-2.2	0.4-1	1.3	0.6	5.2	1600
BLD2	2.2-4.4	1-2	1.3	0.6	5.2	1600
BLD3	4.4-6.6	2-3	1.3	0.7	5.2	1600

Medium Duty – Capacity 2.2 to 26.5 lbs. (1 to 12 kg)

- Safety device prevents dropping of load due to spring breakage (except BMDS-2)
- Anti-friction cable guide
- Adjustable stroke limiting device

Model No.	Capacity		Weight		Lift	
	lb.	kg	lb.	net-kg	ft.	mm
BMDS-2	2.2-5.5	1-2.5	4.4	2.0	6.5	2000
BMDS-4	4.4-8.8	2-4	4.4	2.0	6.5	2000
BMDS-6	8.8-13.2	4-6	5.1	2.3	6.5	2000
BMDS-8	13.2-17.6	6-8	5.5	2.5	6.5	2000
BMDL-4	4.4-8.8	2-4	6.4	2.9	8.2	2500
BMDL-6	8.8-13.2	4-6	7.1	3.2	8.2	2500
BMDL-8	13.2-17.6	6-8	7.7	3.5	8.2	2500
BMDL-10	17.6-22.0	8-10	8.2	3.7	8.2	2500
BMDL-12	22.0-26.5	10-12	8.8	4.0	8.2	2500

Locking Type Balancer

Model No.	Capacity		Weight		Lift	
	lb.	kg	lb.	net-kg	ft.	mm
BMDLL-4	4.4-8.8	2-4	6.6	3.0	8.2	2500
BMDLL-6	8.8-13.2	4-6	7.3	3.3	8.2	2500
BMDLL-8	13.2-17.6	6-8	7.9	3.6	8.2	2500
BMDLL-10	17.6-22.0	8-10	8.4	3.8	8.2	2500

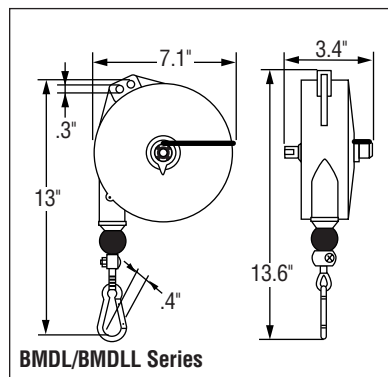
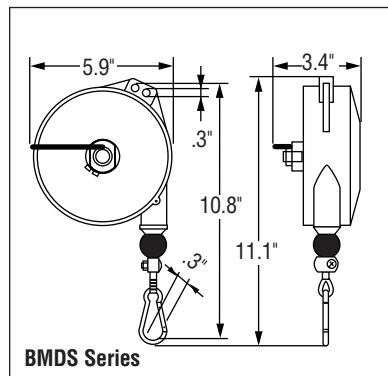
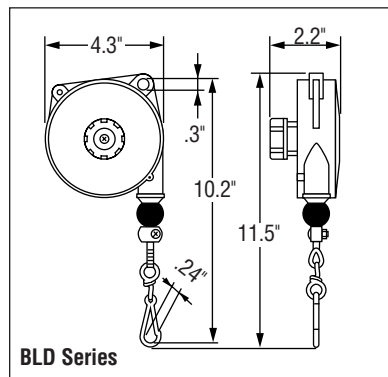
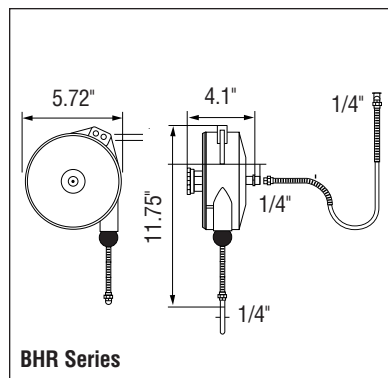

Intermediate Duty – Capacity 8 to 55 lbs. (4 to 25 kg)

- Safety device prevents load dropping due to spring breakage
- Anti-friction cable guide
- Adjustable stroke limiting device
- Upper rotary suspension
- Safety hook
- Auxiliary safety suspension

Model No.	Capacity	
	lb.	kg
BIDS-7	8.8-15.4	4-7
BIDS-10	15.4-22	7-10
BIDS-14	22-30.8	10-14
BIDS-18	30.8-39.6	14-18
BIDS-22	39.6-48.4	18-22
BIDS-26	48.4-55	22-25

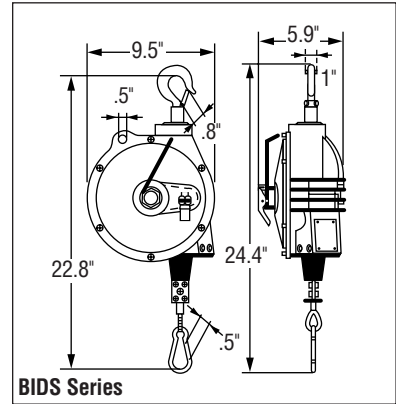

Heavy Duty – Capacity 22 to 143 lbs. (10 to 65 kg)

- Safety device prevents load dropping due to spring breakage
- Upper suspension with rotary safety hook
- Precision guided cable winding prevents jamming
- Anti-friction cable guide
- Manual locking device for instant clamping or release
- Worm screw capacity adjustment
- Spring drum assembly
- Floor controlled locking device available as an option (BIL-7343)

Model No.	Capacity		Weight		Lift	
	lb.	kg	lb.	net-kg	ft.	mm
BHD-15	22-33	10-15	22.7	10.3	6.5	2000
BHD-20	33-44	15-20	23.4	10.6	6.5	2000
BHD-25	44-55	20-30	25.4	11.5	6.5	2000
BHD-30	55-66	25-30	25.4	11.5	6.5	2000
BHD-35	66-77	30-35	26.0	11.8	6.5	2000
BHD-45	77-99	35-45	27.3	12.4	6.5	2000
BHD-55	99-121	45-55	27.6	12.5	6.5	2000
BHD-65	121-143	55-65	30.0	13.6	6.5	2000

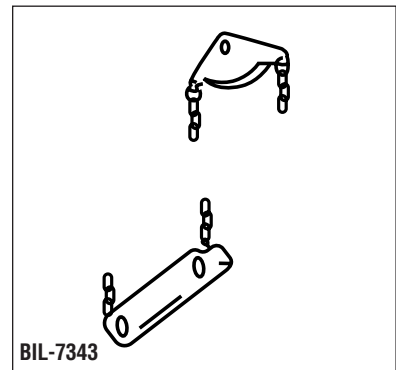
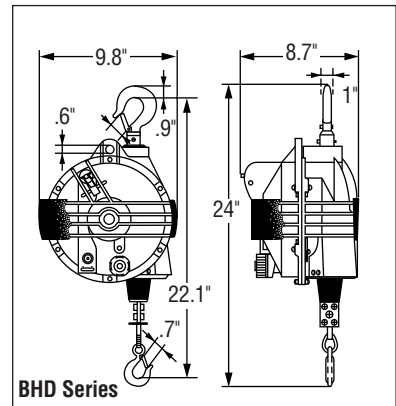

Balancers

Super Duty — Capacity 33 to 363 lbs. (15 to 165 kg)

- Safety device prevents load dropping due to spring breakage
- Manual locking device for instant clamping or release
- Anti-friction cable guide
- Cable replacement without balancer disassembly
- Floor controlled locking device available as an option (BIL-7343)
- Precision guided cable winding prevents jamming

- Alignable rotating upper hook
- Worm screw capacity adjustment
- Cable visible for inspection
- Other sizes available on request

Model No.	Capacity		Weight		Lift	
	lb.	kg	lb.	net-kg	ft.	mm
BSD-20	33-44	15-20	41.9	19.0	8.2	2500
BSD-30	44-66	20-30	43.7	19.8	8.2	2500
BSD-40	66-88	30-40	45.9	20.8	8.2	2500
BSD-50	88-110	40-50	52.7	23.9	8.2	2500
BSD-60	110-132	50-60	56.0	25.4	8.2	2500
BSDL-20	33-44	15-20	42.1	19.1	9.85	3000
BSDL-25	44-55	20-25	43.9	19.9	9.85	3000
BSDL-35	55-77	25-35	46.1	20.9	9.85	3000

Model No.	Capacity		Weight		Lift	
	lb.	kg	lb.	net-kg	ft.	mm
BSD-70	132-154	60-70	59.1	26.8	8.2	2500
BSD-80	154-176	70-80	61.3	27.8	8.2	2500
BSD-90	176-198	80-90	63.5	28.8	8.2	2500
BSDL-45	77-99	35-45	52.5	23.8	9.85	3000
BSDL-50	88-110	40-50	52.7	23.9	9.85	3000
BSDL-60	110-132	50-60	55.8	25.3	9.85	3000
BSDL-70	132-154	60-70	58.9	26.7	9.85	3000
BSDL-80	154-176	70-80	61.7	28.0	9.85	3000
BSDL-90	176-198	80-90	64.0	29.0	9.85	3000

Model No.	Capacity		Weight		Lift	
	lb.	kg	lb.	net-kg	ft.	mm
BSD-100	198-220	90-100	78.5	35.6	8.2	2500
BSD-120	220-265	100-120	85.3	38.7	8.2	2500
BSD-140	265-309	120-140	92.2	41.8	8.2	2500
BSD-150	287-330	130-150	98.1	44.5	8.2	2500
BSD-165	330-363	150-165	106.3	48.2	8.2	2500
BSDL-100	198-220	90-100	81.1	36.8	9.85	3000
BSDL-115	220-254	100-115	85.3	38.7	9.85	3000
BSDL-130	254-286	115-130	88.0	39.9	9.85	3000
BSDL-140	286-309	130-140	94.4	42.8	9.85	3000
BSDL-150	309-330	140-150	100.6	45.6	9.85	3000

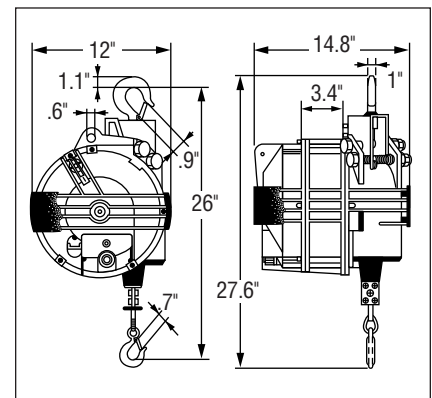
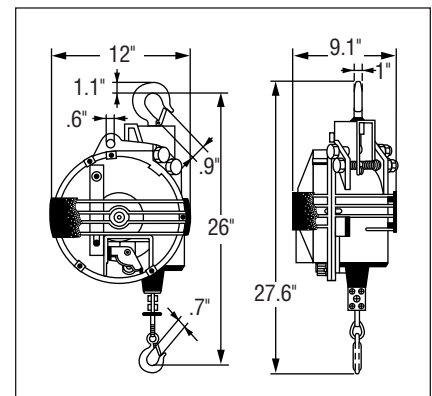
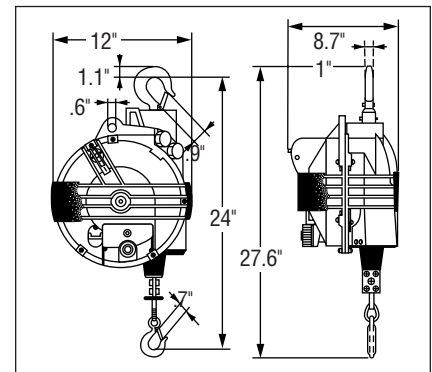

Comfort Grips

Made from energy-absorbing Sorbothane®, the IRAX Comfort Grip provides an isolation barrier between your operator and the tool. Sorbothane®, proven effective in absorbing mechanical shocks and reducing vibrations transmitted to the operator, has been tested and recommended for years in medical and athletic applications.

Features

- Nonslip urethane outer skin
- Die cut for precise tool fit
- Also available in sheet form
- Self-stick adhesive backing
- -20°F to 180°F operating range
- .125" thickness



Impactools	Part Number
1702P & 212 Pistol	CG-1702P
231, 2705A Pistol	CG-2705
2707A & 244P Pistol	CG-2707
2906P Pistol	CG-2906
2920P Pistol	CG-2920P
2940P	CG-2940P
1702SB & 212B	CG-1702
1720P & 261P	CG-1720P
1712, 2934, 2940, 2945, 2950, 280	CG-2934BA
For Other Applications	
6" x 8" Sheet with Tape	CG-6X8
42" Roll Seam Tape	CG-ST42

Blow Guns

- Designed to meet OSHA standards
- Available in standard, 6" and 12" lengths
- Cushioned thumb grip

600 Series

Multiple venturi holes maximize air volume while conforming to OSHA's requirements on compressed air.

- Used for cleaning

600-S



606-S and 612-S



ST206 and ST212



8338-1

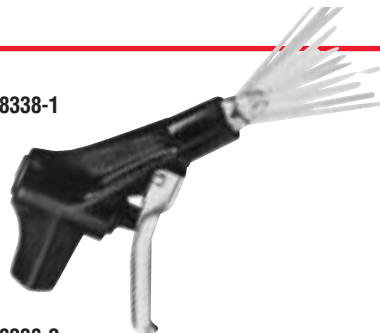

8338-2



8440



ST10



ST11



Part Number	Description
600 Series†	
600-S	Standard Safety Blow Gun
600-SB	Booster Safety Blow Gun
606-S	Safety Blow Gun w/6" Extension
612-S	Safety Blow Gun w/ 12" Extension
8338 Series*	
8338-1	Safety Blow Gun with Cone of Air
8338-2	Safety Blow Gun with Rubber Tip
33970	10" Extension Tip for 8338 Series
8440 Series*	
8440	Safety Yellow, Lightweight, Polyester Blow Gun
Safety Extensions – Used on 600 Series	
ST206	6" Safety Extensions
ST212	12" Safety Extensions
Blow Gun Tips – Used on 600 Series	
ST10	Standard Safety Tip
ST11	Safety Air Booster Tip

¼" NPT – Maximum Tip Pressure 30 psig per OSHA Requirement.

* Maximum Inlet Pressure 250 psig.

† Maximum Inlet Pressure 150 psig.

Lubricants

Lubrication

Proper lubrication of air tools is a must to prevent excessive wear of moving parts; to prevent possible rust and corrosion of bare, unprotected surfaces; and to provide smooth operation of motors, impact mechanisms, and other important components. Ingersoll-Rand has a full line of oils and greases which has been tested thoroughly and is recommended without reservation.



Oils Part Number	Oil Number	Quantity	Recommended Use
63Z4	63	4 oz.	Cyclone Wick Lubricant
Chain Lubricant			
Lubri-Link-Green		16 oz. Spray Bottle	Lubricant
LLG-5		5 gal.	
Class I Lubricant			
10Z4	10	4 oz.	For Percussive Tools, Assembly Tools and Series CD, CX, CA, TD, TX, TA and TXA Grinders
10P		1 pt.	
10G		1 gal.	
10G55		55 gal.	
Class II Lubricant			
50P	50	1 pt.	Motors of Series 1, 61, 77, 88 and 99 Grinders, Impacttools, Sump Pumps, Vibrators, Saws, Hoists and Winches
50G	50	1 gal.	
62 1 Gal		1 gal.	Hoist & Winch Gear Boxes

Greases Part Number	Grease Number	Quantity	Recommended Use
23-1 LB	23	1 lb	Gearing of Drills
28 1 LB	28	1 lb	Screwdriver Gearing and Clutches; Drills, Grinders, Saws; Tie Tampers
28 8 LB		8 lb	
66 1 LB	66	1 lb	Slow Speed, High Torque Angle Heads
66 8 LB		8 lb	
67-4T	67	4 oz.	High Speed Angle Heads-High Temp (Green)
67-1 LB	67	1 lb	
67 8 LB		8 lb	
68-1 LB	68	1 lb	Coupling Splines and High Speed Angle Heads
68 8 LB	68	8 lb	
70 1 LB	70	1 lb	Large Piston Motor Gear Cases
70 8 LB		8 lb	
80 1 LB	80	1 lb	Bearings of All Sump Pumps
80 8 LB		8 lb	
90-14 oz	90	14 oz.	Offset Gear Heads for Tube Nut Wrenches
100 1 LB	100	1 lb	Impact Mechanisms of Most Impacttools
100 8 LB		8 lb	
105-4T-6 ⁽¹⁾	105	4 oz. tube	Impact Mechanisms of Most Impacttools and for Assembly of 2131 Impact Mechanisms.
105-1 LB		1 lb	
105-8 LB		8 lb	
115-4T-6 ⁽¹⁾	115	4 oz. tube	For General Maintenance on 2131 Impacttool Mechanisms
115-1 LB		1 lb	
150-1 LB	150	1 lb	All Impact Mechanisms with Swinging Weight (900 Series)
150 8 LB		8 lb	

⁽¹⁾ Six tubes of 105 grease

Anti-Freeze	
Part Number	Quantity
10GW	1 gal.

Rock Drill Oil		
Part Number	Quantity	
51378701	1 gal.	Light Below 20°F or (6.7°C)
51378693	1 gal.	Medium 20°-90°F (-6.7° to 32.2°C)

Air Care Kits	
Part Number	General Description
67-LBK1	Angle Grinder Gear
105-LBK1	Impacttools Mechanisms, Greased via rear of tool.
115-LBK1	2131 Series



Grease Guns		
Part Number	Quantity	General Description
P25-228	3 oz.	Push-type Hand Gun for Hydraulic-type Fittings
R000A2-228	3 oz.	Push-type Hand Gun for Flush-type Fittings
GTH-1		For Grease Tubes



R000A2-228



P25-228

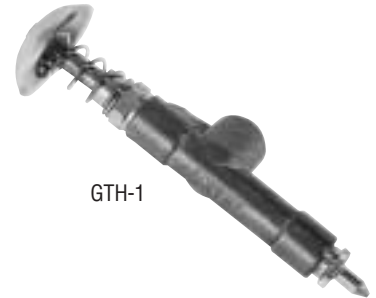

GTH-1

Tune-Up Kits

Impacttools Tune-Up Kit Number	Tools Used On
1702B-TK2	1701B, 1702B, 2902B, 212B
1702P-TK2	1701P, 1702P, 2902P, 212P
1702SB-TK2	1702SB, 2902SB
1705P-TK2	1705P1
1709P-TK2	1709P
1710B/1710P-TK3	1710B1, 1710P1, 1711B3, 1711P3
1712B/1712P-TK3	1712B2, 1712B4, 1712P1, 280
1720B-TK2	1720B, 261B
1720P-TK2	1720P, 261P
2131P-TK2	2131P
2131-K36	2131 Seal Kit
2131P-THK1	Hammer Kit
221-TK2	221
223-TK2	223
231-TK3	231, 251P
2705-TK3	2705, 251P
2706-TK3	2706

Impacttools Tune-Up Kit Number	Tools Used On
2707-TK2	2707A1, 2707A7, 244P
2903P-TK2	2903P1, 2903P2, 2903P7
2904P-TK2	2904P1, 2904P2, 2904P4
2905P-TK2	2905P1, 2905P7
2906P-TK1	2906P1, 2906P7
2908P-TK2	2908P
2910-TK4	2910B, 2910P
2920B-TK2	2920B
2920P-TK2	2920P
2161-TK2	2161, 2171
2925-TK2	2925
2934-TK3	2934, 2934P
2940-TK3	2940, 2940P
2945-TK2	2945
2950-TK2	2950
5020-TK2	5020, 5020H, 5020T, 5020TH
5040-TK2	5040, 5040T, 5040TD, 5040TDQ

Hose Couplings

Universal Hose Couplers

(full flow non-shutoff; shutoff air supply before disconnecting.)

Gaskets and clip are included with all Universal Couplers.

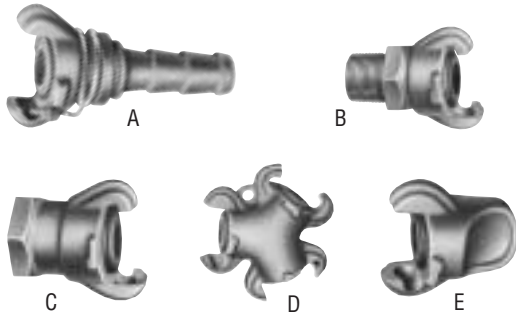

Universal Coupler Gasket



For use in any Universal Coupler, Part Number UG-100.





Description and Illustration	Malleable Part Number	Bronze Part Number	Hose Size in.
A Universal Hose End	UH-50-M		1/2
	UH-75-M		3/4
	UH-100-M		1
B Universal Male Pipe Threaded End	UM-37-M		3/8
	UM-50-M		1/2
	UM-75-M		3/4
	UM-100-M		1
C Universal Female Pipe Threaded End	UF-50-M		1/2
	UF-75-M		3/4
	UF-100-M		1
D Universal 3-Way	UW-300-B		1/4 to 1
E Universal Dead End	UD-301-M		1/4 to 1

O-Rings for Type A Couplings Part Number	Body Size	Used in Model
BU-948	5/8"	FH, FO, MDY, MY
R4-103	1"	FH, FO, CA

Type A Hose Couplers

(full flow non-shutoff; turn off air supply before disconnecting.)

The IR type "A" couplers come in 5/8" and 1" body sizes. Designed for heavy duty service, the type "A" couplers are simple, sturdy and able to withstand hard usage and abuse without affecting their efficiency. Type "A" couplers and plugs are compatible within the same "Body" size.

Type	Body Size	Part Number	Max. Flow Opening	"A" End Size in.
A 	5/8"	MH-8-1/2	3/8"	1/2" Hose
	5/8"	MH-8-3/4	5/8"	3/4" Hose
	1"	MH-8A-1	13/16"	1" Hose
A 	5/8"	MO-8-1/2	3/8"	1/2" MNPT
	5/8"	MO-8-3/4	5/8"	3/4" MNPT
	1"	MO-8A-1	13/16"	1" MNPT
A 	5/8"	FH-8-1/2	3/8"	1/2" Hose
	5/8"	FH-8-3/4	9/16"	3/4" Hose
	1"	FH-8-1	13/16"	1" Hose
A 	5/8"	FO-8-3/8	3/8"	3/8" MNPT
	5/8"	FO-8-1/2	1/2"	1/2" MNPT
	5/8"	FO-8-3/4	5/8"	3/4" MNPT
	1"	FO-8-1	15/16"	1" MNPT

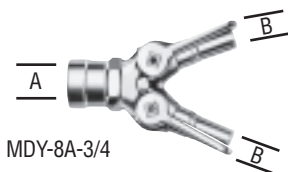

MDY-8A-3/4

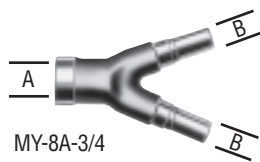

MY-8A-3/4



CA-8A

Adapters Description	Body Size	Part Number	Max. Flow Opening	"A" End Size in.	"B" End Size in.
"Y" Shut off Valve	5/8"	MDY-8A-3/4	1/2"	1/2" Female	1/2" Plug
"Y" Adapter	5/8"	MY-8A-3/4	1/2"	1/2" Female	1/2" Plug
1" to 1/2" Reducer	1"	CA-8A*	5/8"	1" Female	1/2" Plug

*CA-8A Reduces from the 1" body size down to a 3/4" NPT female thread. It comes with one MO-8-1/2 screwed into the "B" end.

Swivel-It!™

Introducing the *NEW*, non-marring, composite *Swivel-It* from Ingersoll-Rand. The *NEW Swivel-It* is made from non-marring, high impact, chemical resistant composite material. The *NEW* composite *Swivel-It* is available in 1/4" NPT and provides 32% more air flow with 33 scfm.

The adjustable 1/4" NPT *Swivel-It* as well as the 3/8" NPT and 1/2" NPT are currently available only in aluminum. Look for additional *Swivel-It* models available in composite.

The *Swivel-It* is designed to reduce operator fatigue by allowing the air hose to hang straight to the floor, enhancing maneuverability and increasing operator comfort and productivity. For use with drills, screwdrivers, impact tools, angle wrenches, grinders, polishers, and sanders. Not for use with percussive tools.

Thread Size	Part Number	Air Flow Range
1/4"	ASC-1/4 ⁽²⁾	0-25 cfm Adjustable
1/4" ⁽¹⁾	ASA-1/4	0-25 cfm Non-Marring
3/8"	AS-3/8	0-45 cfm Standard
1/2"	AS-1/2	0-65 cfm Standard

⁽¹⁾ Adjustable air flow
⁽²⁾ Composite



ASC-1/4

PR Series (Quick Connect Composite Safety Couplers)



PR Couplers IR Part	Description	Avg. Flow CFM
PRSGF22	1/4" FNPT 1/4" Body, Safety Coupler	32
PRSGF23	3/8" FNPT 1/4" Body, Safety Coupler	32
PRSGF33	3/8" FNPT 3/8" Body, Safety Coupler	64
PRSGF34	1/2" FNPT 3/8" Body, Safety Coupler	64
PRSGM22	1/4" MNPT 1/4" Body, Safety Coupler	32
PRSGM23	3/8" MNPT 1/4" Body, Safety Coupler	32
PRSGM33	3/8" MNPT 3/8" Body, Safety Coupler	64
PRSGM34	1/2" MNPT 3/8" Body, Safety Coupler	64
PRSGH22	1/4" ID Hose 1/4" Body, Safety Coupler	32
PRSGH23	3/8" ID Hose 1/4" Body, Safety Coupler	32
PRSGH33	3/8" ID Hose 3/8" Body, Safety Coupler	64
PRSGH34	1/2" ID Hose 3/8" Body, Safety Coupler	64

PR Connectors IR Part	Description
PRPF22	1/4" FNPT 1/4" Body, Connector
PRPF23	3/8" FNPT 1/4" Body, Connector
PRPF32	1/4" FNPT 3/8" Body, Connector
PRPF33	3/8" FNPT 3/8" Body, Connector
PRPM22	1/4" MNPT 1/4" Body, Connector
PRPM23	3/8" MNPT 1/4" Body, Connector
PRPM32	1/4" MNPT 3/8" Body, Connector
PRPM33	3/8" MNPT 3/8" Body, Connector
PRPH22	1/4" ID Hose 1/4" Body, Connector
PRPH23	3/8" ID Hose 1/4" Body, Connector
PRPH33	3/8" ID Hose 3/8" Body, Connector
PRPH34	1/2" ID Hose 3/8" Body, Connector

Impactools Index

(Alpha order / Numerical order by first letter / Digit of model)

MODEL	DESCRIPTION	PAGE	MODEL	DESCRIPTION	PAGE	MODEL	DESCRIPTION	PAGE
1702P1	3/8" CLASS IMPACTOOL	5	2908P1	3/4" CLASS IMPACTOOL	10	2950A7	1 1/2" CLASS IMPACTOOL	14
1702P4	3/8" CLASS IMPACTOOL	5	2908P2	3/4" CLASS IMPACTOOL	10	2950B1	1 1/2" CLASS IMPACTOOL	14
1702SB1	3/8" CLASS IMPACTOOL	5	2920B1	3/4" CLASS IMPACTOOL	10	2950B7	1 1/2" CLASS IMPACTOOL	14
1712B2	1" CLASS IMPACTOOL	12	2920B3	3/4" CLASS IMPACTOOL (1")	10	588A1	2 1/2" CLASS IMPACTOOL	15
1712P2	1" CLASS IMPACTOOL	12	2920B9	3/4" CLASS IMPACTOOL	10	599A1	3 1/2" CLASS IMPACTOOL	15
1720B1	3/4" CLASS IMPACTOOL	10	2925P1	3/4" CLASS IMPACTOOL	10	5020TAH1	TORQUE CONTROL IMPACTOOL	19
1720B3	3/4" CLASS IMPACTOOL (1")	10	2925P3	3/4" CLASS IMPACTOOL	10	5020TAL1	TORQUE CONTROL IMPACTOOL	19
1720P1	3/4" CLASS IMPACTOOL	10	2925RBP1	3/4" CLASS IMPACTOOL	10	5020TDQ	TORQUE CONTROL IMPACTOOL	19
1720P3	3/4" CLASS IMPACTOOL (1")	10	2925RBP3	3/4" CLASS IMPACTOOL	10	5040TAH1	TORQUE CONTROL IMPACTOOL	19
1734A1	1" CLASS IMPACTOOL	12	2934A2	1" CLASS IMPACTOOL	12	5040TAL1	TORQUE CONTROL IMPACTOOL	19
2131P	1/2" CLASS IMPACTOOL	6	2934B1	1" CLASS IMPACTOOL	12	5040TAM1	TORQUE CONTROL IMPACTOOL	19
2131P7	1/2" CLASS IMPACTOOL (7/16")	6	2934B2	1" CLASS IMPACTOOL	12	5040TDQ	TORQUE CONTROL IMPACTOOL	19
2161P	3/4" CLASS IMPACTOOL	10	2934B9	1" CLASS IMPACTOOL	12	5980A1	1 1/2" CLASS IMPACTOOL	14
2171P	3/4" CLASS IMPACTOOL	10	2934P2	1" CLASS IMPACTOOL	12	5982A1	2 1/2" CLASS IMPACTOOL	15
2705A1	1/2" CLASS IMPACTOOL	6	2940A1	1" CLASS IMPACTOOL	13	8005	ELECTRIC IMPACTOOL	22
2707A1	1/2" CLASS IMPACTOOL	6	2940A2	1" CLASS IMPACTOOL	13	8049	ELECTRIC IMPACTOOL	22
2902P1	3/8" CLASS IMPACTOOL	5	2940B1	1" CLASS IMPACTOOL	13	8053	ELECTRIC IMPACTOOL	22
2903P1	1/2" CLASS IMPACTOOL	6	2940B2	1" CLASS IMPACTOOL	13	8053QC	ELECTRIC IMPACTOOL	22
2903P2	3/8" CLASS IMPACTOOL	5	2940P2	1" CLASS IMPACTOOL	13	8055	ELECTRIC IMPACTOOL	22
2904P1	3/8" CLASS IMPACTOOL	5	2945A7	1 1/2" CLASS IMPACTOOL	14	8056	ELECTRIC IMPACTOOL	22
2904P2	1/2" CLASS IMPACTOOL	6	2945B1	1 1/2" CLASS IMPACTOOL	14	8062	ELECTRIC IMPACTOOL	22
2906P1	1/2" CLASS IMPACTOOL	6	2945B7	1 1/2" CLASS IMPACTOOL	14			

Contact Information

United States

Marketing/Sales/Service Headquarters

Ingersoll-Rand Tool and Hoist Division
1467 Rte. 31 South
Annandale, NJ 08801
Telephone: (908) 238-7000
Fax: (908) 238-7052

Distribution Center

Ingersoll-Rand Tool and Hoist Division
510 Hester Drive
White House, TN 37188
Telephone: (615) 672-0321
Fax: (615) 672-0801

Central Regional Office

Ingersoll-Rand Tool and Hoist Division
131 W. Diversey Avenue
Elmhurst, IL 60126-1102
Telephone: (630) 530-3873
Fax: (630) 530-3891

Detroit/Metro Regional Office

Ingersoll-Rand Tool and Hoist Division
1872 Enterprise Drive
Rochester Hills, MI 48309
Telephone: (248) 293-5700
Fax: (248) 293-5807

Eastern Regional Office

Ingersoll-Rand Tool and Hoist Division
900 East 8th Avenue, Suite 103
King of Prussia, PA 19406
Telephone: (610) 337-5930
Fax: (610) 337-5912

Southern Regional Office

Ingersoll-Rand Tool and Hoist Division
450 Gears Road, Suite 210
Houston, TX 77067-4516
Telephone: (281) 872-6800
Fax: (281) 872-6807

Western Regional Office

Ingersoll-Rand Tool and Hoist Division
13107 Lakeland Road
Santa Fe Springs, CA 90670
Telephone: (562) 777-0808
Fax: (562) 777-0818

Canada

Marketing/Sales/Service Headquarters

Ingersoll-Rand Canada Inc.
51 Worcester Road
Toronto, Ontario M9W 4K2
Telephone: (416) 213-4500
Fax: (416) 213-4510

Alberta

Ingersoll-Rand Canada Inc.
9720-54 Avenue
Edmonton, Alberta T6E 0A9
Telephone: (780) 438-5039
Fax: (780) 430-4500

Quebec

Ingersoll-Rand Canada Inc.
3501 St. Charles Blvd. Suite 104
Kirkland, Quebec H9H 4S3
Telephone: (514) 695-9040
Fax: (514) 695-0963

British Columbia

Ingersoll-Rand Canada Inc.
1200 Cliveden Ave.
Delta, B.C. V3M 6G4
Telephone: (604) 523-0803
Fax: (604) 523-0801

Latin America

Marketing/Sales/Service Headquarters

Ingersoll-Rand Company
730 N.W. 107th Ave. Suite 300
Miami, FL 33172-3107
Telephone: (305) 559-0500
Fax: (305) 222-0864

Brasil

Ingersoll-Rand do Brasil Ltda.
Tool & Hoist Division
Av. Dr. Cardoso de Melo 1855
cj. 152-04548-005 Sao Paulo., SP
Brasil
Telephone: (55) 11 3049-8900
Fax: (55) 113846-4985

Chile

Ingersoll-Rand Chile
Nueva Tajamar 555, 15th fl.
Las Condes, Santiago
Chile
Telephone: (56) 2 339-7939
Fax: (56) 2 339-7940

Mexico

Ingersoll-Rand S.A. de C.V.
Tool & Hoist Division
Blvd. Centro Industrial #11
Fracc. Industrial Puente de Vigas, 54090
Tlanepilantla, Edo. de Mexico, Mexico
Telephone: (52) 5 565-3061
Fax: (52) 5 565-3072

Europe/Middle East/Africa

Tool & Hoist Division Headquarters and

European Customer Care Centre
Ingersoll-Rand

Zone du Chêne Sorcier
BP 62
78346 Les Clayes sous Bois Cedex
France
Telephone: +33 (0)1 30 07 68 00
Fax: +33 (0)1 30 07 69 80

Ingersoll-Rand Distribution Centre

Swan Lane
Hindley Green
Wigan
Lancashire WN2 4EZ
England
Phone: +44 (0)1942 257131
Fax: +44 (0)1942 526255

Asia/Pacific

Marketing/Sales/Service Headquarters

Ingersoll-Rand Asia Pacific
23/F., 625 Kings Point Road
North Point
Hong Kong
Phone: (852) 2527 -0183
Fax: (852) 2529 -5976

Australia

Ingersoll-Rand Australia, Ltd.
1 Hartnett Drive
Mail: PMB 2, Carrum Downs BC, Vic., 3201
Seaford, Victoria 3198
Australia
Phone: (61) 3 9554 1600
Fax: (61) 3 9554 1611

India

Ingersoll-Rand Wadco Tools, Ltd.
37A, Site 4
Sahibabad Industrial Area
Ghaziabad 201 010 (UP)
Phone: (91) 0120-4771-001-4
Fax: (91) 0120-4771-005

For additional specific information on Ingersoll-Rand locations in Europe and Asia, visit our website at: www.irtools.com.

Disclaimer: Nothing contained within this brochure is intended to extend any warranty or representation, expressed or implied, regarding the products described herein. Any such warranties or other terms or conditions of the sale of products shall be in accordance with Ingersoll-Rand Standard Terms and Conditions of Sale for such products which are available upon request.

Product improvement is a continuing goal at Ingersoll-Rand. Designs and specifications are subject to change without notice or obligation.



Ingersoll-Rand Company
Tool and Hoist Division
1467 Route 31 South
Annandale, New Jersey 08801
www.irtools.com